

# **Industrial Wireless Technology for Railway Systems**

## Executive Summary

Fast, convenient, safe and reliable transportation is the ultimate goal for people traveling, whether for business or pleasure. As rail operators seek to encourage people to abandon their individual vehicles in favor of public transportation options, they need to keep up with the latest technological advancements and customer expectations.

From personal Internet access via smartphones, to instant on-board entertainment options, to up-to-date travel information – passenger demands on public transportation continue to increase. These offerings are no longer luxuries, they're necessities. To reliably deliver these wireless technologies, as well as manage and control today's modern transportation systems, the network infrastructure running behind the scenes needs to be just as sophisticated.

For several years now, industrial automation applications have been abandoning conventional fieldbus technology in favour of industrial Ethernet. While traditional fieldbus technology is relatively simple and extremely reliable, Ethernet offers many added benefits, including additional flexibility, ease of use and real-time communication.

Previously, many of the transportation network devices and protocols were incompatible and systems could not be interconnected to achieve the single integrated network that is now needed. With industrial Ethernet's ability to network individual subscribers and use standardised global technology (IEEE 802.3<sup>1</sup>), the entire passenger train has now become one integrated industrial Ethernet-based network.

Industrial Ethernet-based network architectures bring a number of benefits, such as system interconnection, greater flexibility and ease of adding wireless local area networks (WLANs), which all open up possibilities for new applications and passenger services.

In this white paper, we will discuss how wireless technology in industrial transportation settings, specifically the railway industry, can help meet customer demands and incorporate the latest technology, while also delivering uncompromising safety and minimal downtime or delays. When we consider the railway industry, this includes everything from high-speed trains connecting states or countries, to light rail, subway or metro systems within major cities.

## 3 Trends Driving the Need for Wireless Technology

There are three primary areas that showcase why wireless technology is becoming essential in modern railway systems.

1. Passenger Expectations – Against a backdrop of passenger needs, rail operators are looking to shift travellers' mode of transportation from road to rail. One clear differentiator – and a major aspect driving this change – is rail operators' ability to provide on-board wireless Internet access. An analysis of passengers who travelled on the Capitol Corridor route along the U.S. West Coast in 2012 showed that offering free wireless Internet access leads to approximately a 3 percent increase in passengers<sup>2</sup>. In addition to Wi-Fi, real-time passenger information systems are expected to provide live, up-to-date travel information about arrival times, connecting trains and platform numbers. On-board entertainment, including the availability of movies and TV shows, is another interest area – and industrial wireless products are the key enablers for all of these passenger services.

2. Flexible Configurations – In order to maximise profit and keep costs down, trains are often reconfigured to accommodate changing capacity needs – whether it's more or less passengers. For example, groups of rail cars, called train "consists" or "formations," are added together during rush hour when the crowds of people taking public transportation are at their highest. Subsequently, during lulls, rail operators can decrease the number of rail cars in operation. These configuration changes are often conducted at train stations, where the process of coupling and de-coupling rail cars can be difficult and time consuming. Wireless technology, however, provides the ideal solution to this connection challenge – offering a faster and safer connection process.
3. Productivity Demands – Performance requirements for trains are becoming more demanding with the desire for better fuel efficiency, improved reliability, shorter dwell times at platforms, reduced headway between trains, fewer on-board staff (perhaps no driver) and enhanced security. This means the demand for diagnostic and control systems is also increasing. To ensure passenger trains perform as expected, data collection and monitoring must occur across a range of on-board systems, and increasingly, the data flow does not stop there. Diagnostic systems now report back to depots before the train arrives for maintenance so that spare parts and tools can be organised. Seat reservation and ticketing systems provide passengers with real-time travel information. Communications Based Train Control (CBTC) systems facilitate the control and movement of trains remotely using wireless technology. The examples –and application possibilities of wireless technology – are seemingly endless.

### Industrial Wireless Considerations and Challenges

While there are many benefits to wireless technology and its ability to address these key trends, it's also important to consider some of the challenges faced by the railway industry when adding wireless capabilities to on-board environments.

Uncompromising traffic safety and high-availability networks are a top priority for the transportation industry. All industries have specific protocols to follow and certifications to secure, and the railway industry is no different. Stringent specifications are in place, and are a prerequisite for any wireless networking and connectivity equipment installed by rail operators or system integrators.

These standards include:

- **Global:** International Electro Technical Commission (IEC)<sup>3</sup>
- **Europe:** European Standard (EN)<sup>4</sup>
- **North America:** Association of American Railroads (AAR)<sup>5</sup>, American Railway Engineering and Maintenance-of-Way Association (AREMA)<sup>6</sup> and Underwriters Laboratories (UL) Standards<sup>7</sup>

The two most common standards accepted as almost being mandatory include:

- **EN 50155**, which applies to all electrical equipment installed on board rail rolling stock cars, covering climatic, physical and electrical requirements
- **EN 45545**, which details the fire and smoke requirements for electrical equipment installed on board rail rolling stock cars

In addition, there are new emerging standards to specify and further define the on-board Ethernet concept, such as:

- IEC EN 613758, which applies to the architecture of data communication systems in open trains, including communication between vehicles, within vehicles and from the train to the ground – all known as the Train Communication Network, or TCN
- IEC EN 625809, which specifies the general architecture of the on-board multimedia and telematic subsystem (OMTS) within a train consist, including video surveillance and closed-circuit television (CCTV system), as well as services for the train driver, crew, passengers, operator and maintainer

Once equipment is installed on a rail car, access to these products may be difficult for future servicing or replacement, and therefore, preventative maintenance must be minimised. Since these activities are limited to pre-planned maintenance periods (i.e., not while in service carrying passengers), reliability is a key requirement for these networks.

Safety is also of paramount importance to the railway industry. When a train is involved in an accident, it can often involve the loss of life, and subsequently, negative media coverage for the company at fault. The standards previously referenced ensure safety is considered at all levels, from the products themselves to the network design. The primary goal is the safe operation of the overall train.

Finally, rail cars are expensive. They cost upwards of \$1.5 million per car and are often leased by the operating company. When a rail car isn't in operation – i.e., not carrying fare-paying passengers – the idle cars are essentially costing the rail operator money. This means that the installation and commissioning of any on-board products must be as simple and straightforward as possible in order to minimise vehicle downtime.

## Successful Integration of Wireless On Board Trains

In order to meet customer expectations, enable flexible train configurations and deliver on enhanced productivity demands, industrial wireless technology must be tapped. The use of wireless Ethernet in trains also offers numerous ways of increasing passenger safety and convenience, and enhancing productivity and flexibility for rail operators.

For a successful integration of industrial wireless products into a railway setting, the following points need to be considered:

- Harsh environment. The railway industry has its own specific challenges when it comes to environmental conditions. Trains need durable products to withstand a great deal of wear from factors, like temperature fluctuations and moisture from rain, snow and sleet. Rail operators need robust products designed and built specifically for the harsh environment found in the railway industry. For example, wireless access points that can be mounted on DIN rails or installed within the train roof space or other networking products that must operate in temperatures from -40°C to +70°C and withstand electrostatic discharge up to 25kV. In addition, to combat any interference, technology that reliably eliminates competing radio frequencies is needed, which guarantees stable wireless connections at all times.
- Redundancy measures. Reliability is key in the transportation industry and trains need fail-safe measures in place to keep their industrial network up and running. Downtime or delays cost money and negatively impact passenger satisfaction. For wireless specifically,

products with built-in parallel redundancy protocol (PRP)<sup>10</sup> can help dramatically improve the reliability and quality of wireless connections. As a result, the loss- and latency-sensitive applications typically found within the railway industry can be successfully operated with industrial wireless technology.

- **Central management.** Wireless networking capabilities also enable remote management and monitoring of the network from a central location, including traffic control and passenger information systems. Network management software, for example, can recognise the topology of a train's on-board network and use the information to assign numbers to rail cars and even specific seats. A snapshot of occupancy within individual cars is also possible.
- **Safety and security measures.** Industrial wireless products can play a major role in enhancing the safety of passengers and the security of the train's network. For instance, IP-based cameras provide train station and rail car surveillance, while wireless access points enable secure wireless transmission of the video information.
- **Standards and certifications.** As outlined previously, the railway industry has specific industrial networking standards to meet, depending on geographic location. And when incorporating wireless technology, it's critical to select networking and connectivity products that also support the IEEE 802.11n<sup>11</sup> transmission standard for WLANs and have the relevant country certifications for the global railway industry.
- **Future trends and expansion.** An industrial Ethernet network is inherently flexible and easily expandable, which makes it ideal for adapting and accommodating future trends in the transportation industry. Ethernet networking permits increasing data speeds and enables flexible programming for modern, high-speed rail technology. Features, like video coverage of platforms for train drivers or front-facing cameras to improve safety, are also enabled through wireless Ethernet technology.

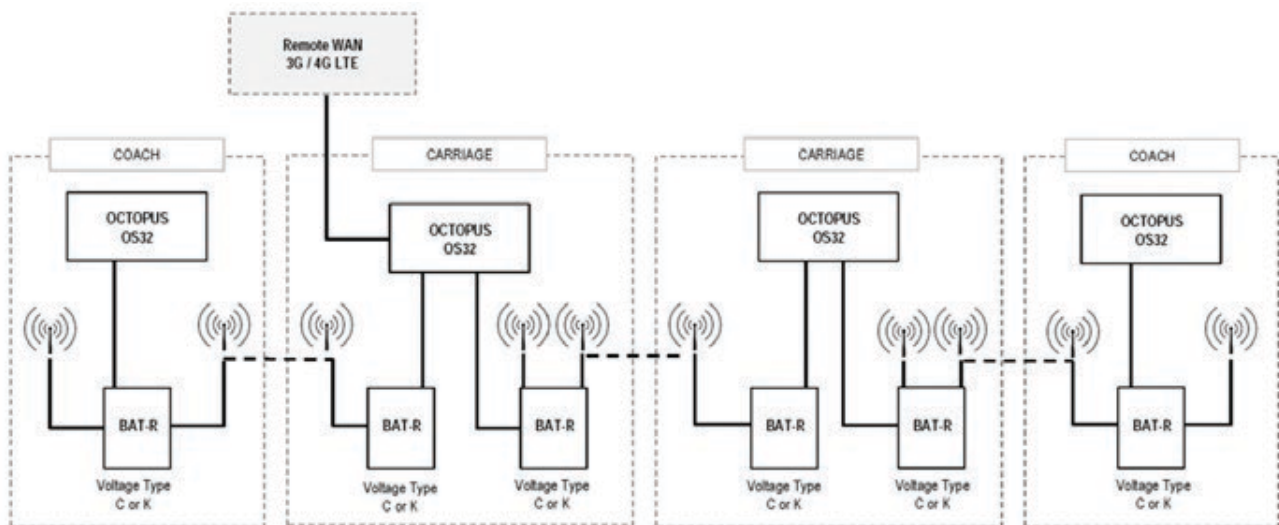

Figure 1: This diagram shows a typical wireless network design for a train in need of on-board wireless connectivity.

Figure 1 depicts a typical wireless network configuration in an on-board railway system. In this scenario, the rail operator sought fast and reliable transmission of operational data and passenger information via an industrial Ethernet infrastructure, plus the interconnection of multiple on-board systems via fast Ethernet switches.

The operator was faced with several challenges for this application, including the need for data connections between rail cars with speeds in excess of 100Mbps and keeping installation to a minimum with little to no impact on existing wiring.

As pictured, the network was segmented into several zones based on physical parameters and each zone is supported by one or two wireless access points (OpenBAT-R) and one industrial Ethernet-managed Gigabit switch (OCTOPUS OS32).

The access points selected offered dual wireless modules, and in some cases, were able to be used for both internal Wi-Fi services and communications between rail cars. This dual function helped minimise potential installation challenges.

Using wireless technology for car-to-car communication is an ideal solution for retrofitting Ethernet services on board trains. Since there is no need to modify the existing car-to-car wiring, costs can be kept low and subsequent safety certifications more straightforward to secure.

The managed Gigabit switches used in this application had Power over Ethernet (PoE) capabilities and were therefore able to power the wireless devices directly over Ethernet. This eliminated the need to install power supplies and cabling for the wireless devices, which also made installation simpler and reduced costs.

The switches also provided local wired connectivity within each rail car for all other Ethernet-based services and applications. With the ability to support up to two Gigabit ports each, the switches will be able to accommodate future data rate increases.

Ultimately, the combination of thoughtful network design and the right products helped this rail operator update and future-proof its network. Tapping into the latest wireless technology made it possible to circumvent the challenges and achieve the defined networking and connectivity goals.

## Summary

Industrial networks in the railway industry should balance the needs of passengers and rail operators, ensuring high levels of reliability, safety and comfort. Taking the challenging rail environment into consideration, the network will require specific products designed for high degrees of resilience, and also meeting the strict standards for redundancy, availability and data security. The integration of wireless networking will bring many benefits to the industry, while introducing some new challenges to manage in order to maintain optimal levels of reliability and performance.

While this white paper has identified several new trends the railway industry is facing, networking technology and customer expectations will continue to evolve.

Rail cars will become progressively more sophisticated and data rates will continue to increase to support new applications. Advancements to industry standards will also continue. This makes a network designed for future upgrades and expansion essential, so that current needs can be met, while also planning ahead for future requirements and trends.

## References

1. 802.3-2012 – Institute of Electrical and Electronics Engineers (IEEE) Standard for Ethernet. <https://standards.ieee.org/findstds/standard/802.3-2012.html>
2. The European Market for Train-Based Wireless Broadband Services 2012. Published by BWCS Ltd. <http://www.bwcs.com/mainsub.cfm?l1=16258&l2=16369>
3. International Electrotechnical Commission (IEC). <http://www.iec.ch/>
4. European Standard (EN). <http://www.cencenelec.eu/standards/DefEN/Pages/default.aspx>
5. Association of American Railroads (AAR). <https://www.aar.org/>
6. American Railway Engineering and Maintenance-of-Way Association. <https://www.arena.org/>
7. Underwriters Laboratories (UL) Standards. <http://ulstandards.ul.com/>
8. IEC EN 61375 "Train Communication Network (TCN)."  
<https://webstore.iec.ch/publication/5397>
9. IEC EN 62580 "Onboard Multimedia and Telematic Subsystems For Railways."  
<https://webstore.iec.ch/publication/21817>
10. White Paper: Parallel Redundancy Protocol Notably Improves Industrial Wireless Reliability. <http://info.belden.com/wireless-cp1-bc-lp>
11. 802.11n-2009 – Institute of Electrical and Electronics Engineers (IEEE) Standard