

---

# PCI247H<sup>2</sup>-9H<sup>2</sup> SERIES

---

---

DUAL CHANNEL PCI  
SERIAL  
COMMUNICATIONS  
BOARD  
WITH ISOLATION  
OPTION

---

This Instruction Manual is supplied with the PCI247H<sup>2</sup>(i), 248H<sup>2</sup>(i) and 249H<sup>2</sup>(i) Series of Serial Data Communications Board to provide the user with sufficient information to utilise the product in a proper and efficient manner. The information contained has been reviewed and is believed to be accurate and reliable, however **Amplicon Liveline Limited** accepts no responsibility for any problems caused by errors or omissions. Specifications and instructions are subject to change without notice.

**PCI247H<sup>2</sup>-9H<sup>2</sup> Series Instruction Manual Part N<sup>o</sup> 986504 Issue C2**

© **Amplicon Liveline Limited**

Prepared by N.Stubbs

Approved for issue by A.S. Gorbald, Operations Director

## DECLARATION OF CONFORMITY

**AMPLICON LIVELINE LIMITED  
CENTENARY INDUSTRIAL ESTATE  
HOLLINGDEAN ROAD  
BRIGHTON BN2 4AW UK**

We declare that the product(s) described in this Instruction Manual are manufactured by Amplicon Liveline Limited and perform in conformity with the following standards or standardisation documents:

EMC Directive 89/336/EEC  
LVD Directive 73/23/EEC  
CE Directive 93/68/EEC



Jim Hicks, I. Eng., FIEIE  
Managing Director  
Amplicon Liveline Limited

**PCI247H<sup>2</sup>(i)-9H<sup>2</sup>(i) Series PCI bus Dual Channel Serial Communications Boards with Isolation Option****LIST OF CONTENTS**

<b>PARA</b>	<b>SUBJECT</b>	<b>PAGE</b>
1	INTRODUCTION	1
1.1	The Amplicon 200 Series	1
1.2	The Products Described in this Manual	1
1.3	Features of the PCI247H <sup>2</sup> -9H <sup>2</sup> Series of Data Communications Boards	1
1.4	General Description	2
1.4.1	Enhanced Features	3
1.5	What the Package Contains	4
1.6	The Amplicon Warranty Covering the PCI247H <sup>2</sup> -9H <sup>2</sup> series of Boards	4
1.7	Contacting Amplicon Liveline Limited for Technical Support or Service	4
1.7.1	Technical Support	5
1.7.2	Repairs	5
2	GETTING STARTED	6
2.1	General Information	6
2.2	Installing the Board	6
2.2.1	Windows 95/98 Installation	7
2.2.2	Windows NT Installation	7
2.2.3	Windows 2000/XP Installation	8
2.2.4	Configuring COM Ports	9
2.2.5	Linux Installation	9
2.3	Card Configuration	9
2.3.1	Configuration Jumper Settings	9
2.3.2	Base Address Selection	9
2.3.3	Interrupt Level Selection (IRQ)	9
2.3.4	RS-485 Full Duplex / Half Duplex Operation	10
2.3.5	Transmission Line Termination	11
2.3.6	Jumper Factory Settings Summary	11
2.4	Application Software	11
2.5	Installation Testing	11
3	MAKING THE CONNECTIONS	13
3.1	External Connections	13
3.2	RS-232 9 way Port	13
3.3	RS-422/485 9 way Port	13
3.3.1	RS-422/485 9 way Port Amplicon pin assignment	14
3.3.2	RS-422/485 9 way Port Alternative pin assignment	14
3.4	Input/Output Connector Locations	15
3.5	Connector Wiring for RS-422/485 Full/Half Duplex	16
3.6	The Ground Connections	16
3.6.1	Ground Connections for Non-isolated Boards	17
3.6.2	Ground Connections for Isolated Boards	17
3.7	Choice of Cable	18
4	USING THE SERIAL COMMUNICATIONS BOARDS	19
4.1	Why Isolate?	19
4.2	Application Notes	21
4.2.1	Applicable Standards	21
4.2.2	RS-232 Application Notes	21
4.3	RS-422/485 Application Notes	22

4.3.1	RS-422/485 Parameters	22
4.3.2	RS-422/485 Signaling Sense	23
4.3.3	RS-422/485 Multi-drop Applications	23
4.3.4	RS-422/485 Bus Termination	24
4.3.5	Cabling of RS-422/485 Bus	25
4.4	Testing and Troubleshooting	25
4.4.1	Testing with the Application Software	25
4.4.2	Testing Using the Supplied Software	26
5	PROGRAMMING	30
5.1	Programming with Windows Device drivers.	30
5.1.1	Half Duplex Transmission Turnaround	30
APPENDIX A	TECHNICAL SPECIFICATIONS	31
App A1	HARDWARE SPECIFICATION	31
App A1.1	Function	31
App A1.2	RS-232 Port	31
App A1.3	RS-422/485 Port	33
App A1.4	Modes	34
App A1.5	UARTS	34
App A1.6	Interrupts	35
App A1.7	Power-up Default	35
App A1.8	PC Interface	35
App A2	SOFTWARE	36
App A3	ENVIRONMENTAL CONDITIONS	36
App A3.1	Environment	36
App A3.2	Specific conditions	36
App A3.3	Electro Magnetic Compatibility	37
App A4	ORDER CODES	37
APPENDIX B	LAYOUT and CIRCUIT Diagrams	38
App B1	Layout Diagrams	38
App B2	PCI247H <sup>2</sup> (i) Circuit and Layout Diagrams	39
App B3	PCI248H <sup>2</sup> (i) Circuit and Layout Diagrams	40
App B4	PCI249H <sup>2</sup> (i) Circuit and Layout Diagrams	41
App B5	Circuit Diagram PCI247H <sup>2</sup> -9H <sup>2</sup> (i) - All Versions	42
App B6	USER'S NOTES - DRAWINGS	43

**LIST OF FIGURES**

<b>FIGURE</b>	<b>TITLE</b>	<b>PAGE</b>
FIGURE 2.1	FACTORY JUMPER SETTING SUMMARY	11
FIGURE 3.1	RS-232 9 WAY PORT PIN DESIGNATIONS	13
FIGURE 3.2	RS-422/485 AMPLICON STANDARD PORT PIN DESIGNATIONS	14
FIGURE 3.3	RS-422/485 ALTERNATIVE STANDARD PORT PIN DESIGNATIONS	14
FIGURE 3.4	INPUT/OUTPUT CONNECTOR LOCATIONS FOR ALL BOARD TYPES	15
FIGURE 3.5	CONNECTIONS FOR FULL AND HALF DUPLEX OPERATION	16
FIGURE 3.6	9 PIN ISOLATED RS-232 CONNECTIONS TO ANOTHER DTE DEVICE	18
FIGURE 4.1	ELIMINATION OF INTERFERING SIGNALS BY ISOLATION	20
FIGURE 4.2	COMMUNICATIONS STANDARDS SUMMARY	23
FIGURE 4.3	RS-422 CONNECTED IN BROADCAST MODE	24
FIGURE 4.4	RS-485 CONNECTED IN MULTI-DROP, HALF DUPLEX MODE	24
FIGURE 4.5	RS-232 9 WAY LOOP-BACK TEST CONNECTIONS	27
FIGURE 4.6	RS-422/485 LOOP-BACK TEST CONNECTIONS	27



## 1 INTRODUCTION

### 1.1 The Amplicon 200 Series

The **Amplicon 200 Series** of Personal Computer based data acquisition, control and communication products provides very high performance, affordable hardware with user sympathetic software. The 200 Series is designed for users requiring fast or complex data input/output to the host PC and comprises a range of boards and software to handle most analog and digital signal types.

When a large-scale system is required, multiple boards can be added from the 200 Series without conflict. In many cases the capacity of the PC mounted hardware can be extended by external expansion and termination panels, which together with the applicable cables, provide a convenient way to use the system with low cost per channel whilst maintaining high performance.

### 1.2 The Products Described in this Manual

The PCI247H<sup>2</sup>-9H<sup>2</sup> Series of communications products includes six variants of dual channel boards with supporting software and accessories. The boards share common circuits and features, and are generically cited in this manual as the PCI247H<sup>2</sup>-9H<sup>2</sup> Series. Where a specific board type, or pair, is referenced, nomenclature as in the following examples is used:-

PCI247H <sup>2</sup> -9H <sup>2</sup> Series	Refers to all boards in the series
PCI247H <sup>2</sup>	Refers to the PCI247H <sup>2</sup> only (Dual channel RS-232)
PCI248H <sup>2</sup> i	Refers to the PCI248H <sup>2</sup> i only (Dual Channel RS-422/485 with isolation)
PCI248/PCI249H <sup>2</sup> (i)	Refers to the PCI248H <sup>2</sup> and/or the PCI249H <sup>2</sup> with or without isolation

### 1.3 Features of the PCI247H<sup>2</sup>-9H<sup>2</sup> Series of Data Communications Boards

Each of the PCI247H<sup>2</sup>-9H<sup>2</sup> Series of boards is designed to meet stringent performance requirements and ease of use while maintaining compatibility with standard serial communications boards.

- PCI Bus version 2.1 plug and play interface
- Windows 95, 98, ME, NT, 2000, and XP drivers
- Linux drivers
- Data rates selectable up to 1 MBaud
- FIFO mode provides input and output data buffers for up to 128 characters
- Three point isolated serial communications on isolated versions
- Two separate, independent serial ports
- Industry standard panel mounted connectors
- Mixed modes. RS-232, 9 way ports, RS-422, RS-485, 9 way ports
- Full Duplex, Half Duplex, Multi-drop applications
- RS-485 transmitter enabled automatically in Special Half Duplex mode
- Full specification signal levels
- Implementation of all RS-232 primary control lines
- Low power consumption

## 1.4 General Description

The PCI247H<sup>2</sup>-9H<sup>2</sup> Series of plug-in boards provides a flexible range of advanced serial communications interfaces for any IBM PC or compatible computers that support the PCI bus version 2.1. The RS-485 ports have a Special Half Duplex mode that causes the transmit buffer to be enabled automatically, by the UART, whenever data is waiting to be sent from the UART Transmit buffer.

All models are supported by Windows 95, 98, ME, NT, 2000 and XP drivers, and Linux drivers. These drivers are a superset of the Microsoft serial drivers and allow the cards to operate as standard serial ports. These drivers also allow the advanced features of the cards to be fully utilised by the application software.

The PCI247H<sup>2</sup>i, PCI248H<sup>2</sup>i and PCI249H<sup>2</sup>i are designed to isolate the serial communications from the computer power. The design is such that it will sustain common mode voltages up to 75Vdc, which is outside of the low voltage directive (73/23/EEC). However in fault conditions they are protected to sustain common mode voltages up to peaks of 1 kVdc.

Six models are available in the range, three of which provide isolation of the data and control lines. The PCI247H<sup>2</sup>i, PCI248H<sup>2</sup>i and PCI249H<sup>2</sup>i boards with isolated input/output circuits will be used in serial communications systems where high integrity data transmission and reception are required in an electrically severe environment. Each board is half-length and supports two independent serial ports designed to meet a combination of the following standards:

RS-232 full duplex serial port furnished with a 9 pin D-type male connector conforming to IBM practice. The port is fully configured with two data, six control I/O lines and one signal return.

RS-485 full duplex, half-duplex, multi-drop operation or RS-422 full duplex with or without RTS-CTS control lines. Depending on the application, RS-485 or RS-422 operation is selected by making the appropriate connections. Each RS-422 / 485 port is furnished with a 9 pin D-type male connector. In addition jumpers have been added to allow the connection to be converted between two common standards found in industry.

For conformance with the latest RS-422/485 standard specifications, the nomenclature of the data lines is amended. The RS-422/485 levels and polarities remain unchanged and the actual external data bus wiring needs no changes.

Serial input/output facilities of the series comprise:

**PCI247H<sup>2</sup>** Provides two independent RS-232 ports, one on each of the upper (port 1) and lower (port 2) channels

**PCI248H<sup>2</sup>** Provides two independent RS-422/485 ports, one on each of the upper (port 1) and lower (port 2) channels

**PCI249H<sup>2</sup>** Provides a 9 pin RS-232 port on the upper channel (port 1) and a 9 pin RS-422/485 port on the lower channel (port 2)

**PCI247H<sup>2</sup>i** Provides an isolated 9 pin RS-232 port on the upper channel (port 1) and a separately isolated 9 pin RS-232 port on the lower channel (port 2)

**PCI248H<sup>2</sup>i** Provides two independent isolated RS-422/485 ports, one on each of the upper (port 1) and lower (port 2) channels

**PCI249H<sup>2</sup>i** Provides an isolated 9 pin RS-232 port on the upper channel (port 1) and a separately isolated 9 pin RS-422/485 port on the lower channel (port 2)

Communications parameters of both ports of all versions are fully programmable for compatibility with other devices connected to the interface and to allow set up by the communications program.

A CD is provided with a program to allow easy testing of the major features of the board when installed in the host PC.

#### **1.4.1 Enhanced Features**

The earlier ISA bus serial cards of the PC247-9 series supported data rates to 115Kbaud and transmit and receive FIFOs up to 16 characters deep. These designs have now been updated to the PC247-9H<sup>2</sup> series which remain ISA bus compatible but have many of the features of this PCI247H<sup>2</sup>-9H<sup>2</sup> Series.

The PCI247H<sup>2</sup>-9H<sup>2</sup> series all support data rates up to 1Mbaud and FIFOs up to 128 characters. In many cases this will give vast performance advantages allowing the processor much more time between serial port services.

The PCI247H<sup>2</sup>-9H<sup>2</sup> range has another special feature if you have an RS-485 Half Duplex or Multi-drop Application. This is Special Half-Duplex mode. In this mode the RS-485 transmit buffer is enabled automatically, by the UART, whenever data is waiting to be sent in the UART Transmit buffer. This feature makes efficient multi-drop communication simple to implement by removing the burden of the Transmit buffer enable control from the software.

## 1.5 What the Package Contains

### CAUTION

Some of the components on the board are susceptible to electrostatic discharge, and proper handling precautions should be observed. As a minimum, an earthed wrist strap must be worn when handling the PCI247H<sup>2</sup>-9H<sup>2</sup> Series board outside its protective bag.

Full static handling procedures are defined in British Standards Publication BSEN100015/BSEN100015-1:1992.

When removed from the bag, inspect the board for any obvious signs of damage and notify Amplicon if such damage is apparent. Do not plug a damaged board into the host computer. Keep the protective bag for possible future use in transporting the board.

The package as delivered from Amplicon Liveline Ltd contains:-

1. The plug-in card as ordered, in a protective bag. The model will be one of the following, and is identified by the type number printed on the board.

<b>PCI247H<sup>2</sup></b>	Dual RS-232 Serial Communications Controller
<b>PCI248H<sup>2</sup></b>	Dual RS-422/485 Serial Communications Controller
<b>PCI249H<sup>2</sup></b>	Single RS-232 plus single RS-422/485 Serial Communications Controller
<b>PCI247H<sup>2</sup>i</b>	Dual RS-232 Serial Communications Controller with I/O signal isolation
<b>PCI248H<sup>2</sup>i</b>	Dual RS-422/485 Serial Communications Controller with I/O signal isolation
<b>PCI249H<sup>2</sup>i</b>	Single RS-232 plus single RS-422/485 Serial Communications Controller with I/O signal isolation

2. The included distribution software and manual on CD
3. Any additional accessories (mating connectors, software etc.) may be packed separately.

## 1.6 The Amplicon Warranty Covering the PCI247H<sup>2</sup>-9H<sup>2</sup> series of Boards

This product is covered by the warranty as detailed in the Terms and Conditions stated in the current domestic or international **Amplicon Liveline Ltd** catalogue.

## 1.7 Contacting Amplicon Liveline Limited for Technical Support or Service

The PCI247H<sup>2</sup>-9H<sup>2</sup> Series boards are designed and manufactured by Amplicon Liveline Ltd and maintenance is available throughout the supported life of the product.

### 1.7.1 Technical Support

Should the board appear defective, please check the information in this manual and any 'Help' or 'READ.ME' files appropriate to the program in use to ensure that the product is being correctly applied.

If an application problem persists, please request Technical Support in one of the following ways:

Web:	www.amplicon.co.uk	
Internet:	<a href="mailto:support@amplicon.co.uk">support@amplicon.co.uk</a>	
Telephone:	UK	01273 608 331
	International	+44 1273 608 331
Fax:	UK	01273 570 215
	International	+44 1273 570 215

It will assist the support engineer if you have the following information available when you call:

- Date of purchase
- Your postcode
- The Operating System you are running under
- The specification of your computer
- The nature of your problem and the results of any tests you have conducted.

You will also be asked if the operating system prompted you for a disk the first time you powered up your computer after insertion of the card.

### 1.7.2 Repairs

If the board requires repair then please return the goods enclosing a repair order detailing the nature of the fault. If the board is still under warranty, there will be no repair charge.

For traceability when processing returned goods, a Returned Materials Authorisation (RMA) procedure is in operation. Before returning the goods, please request an individual RMA number by contacting Amplicon Customer Services by telephone or fax on the above numbers. Please mark the RMA number on the outside of the packaging to ensure that the package is accepted by the Goods Inwards Department.

Give the reason for the return and, if the goods are still under warranty, the original invoice number and date. Repair turnaround time is normally five working days but the Service Engineers will always try to co-operate if there is a particular problem of time pressure.

Address repairs to:

Customer Services Department  
AMPLICON LIVELINE LIMITED  
Centenary Industrial Estate  
Brighton, East Sussex  
BN2 4AW  
England

## 2 GETTING STARTED

### 2.1 General Information

All of the PCI247H<sup>2</sup>-9H<sup>2</sup> Series are Plug and Play and come complete with all the software to install and operate the card in any PCI version 2.1 compliant host PC running under Windows 95, 98, ME, NT, 2000, XP or Linux and allow execution of normal serial communications programs.

Each card takes 260mA from the PC +5 volt rail for the non-isolated cards and 300mA for the isolated cards.

When installing one or more PCI247H<sup>2</sup>-9H<sup>2</sup> Series Data Communications Boards, ensure that the host computer has sufficient capacity. Take into account other boards or adapters that may be installed in the computer when assessing physical space, address space in the I/O map, interrupt levels and the power requirements.

This dual channel serial communications board is suitable for use in any PC compatible computer that can provide a single PCI Bus version 2.1 slot, with sufficient space for a half length card.

The computer must run under one of the following operating systems. Windows 95, Windows 98, Windows Me, Windows NT 4.0, Windows 2000, Windows XP, or Linux.

### 2.2 Installing the Board

**ENSURE THAT THE POWER TO THE COMPUTER IS SWITCHED OFF BEFORE INSTALLING OR REMOVING ANY EXPANSION BOARD. OBSERVE HANDLING PRECAUTIONS NOTED IN SECTION 1.5.**

**REPAIR OF DAMAGE CAUSED BY MIS-HANDLING IS NOT COVERED UNDER THE AMPLICON WARRANTY.**

**DO NOT MAKE ANY MODIFICATIONS OTHER THAN JUMPER CHANGES TO A BOARD THAT IS ON EVALUATION**

Please refer to the manufacturer's hardware manual supplied with the computer for instructions on how to remove the cover and install devices into an input/output slot. The PCI247H<sup>2</sup>-9H<sup>2</sup> Series board may be installed in any available position in the machine provided that there is no restriction specified for that location by the computer manufacturer.

The PCI247H<sup>2</sup>-9H<sup>2</sup> Series board is a Plug and Play device. The installation software supplied will handle all configuration of the card.

When the card is physically installed in the PC. Simply turn on the PC and allow the Windows operating system to discover new hardware. From then on respond to the questions asked. When prompted for a disk use the disk supplied. Under Windows NT, the card will only be accessible *after* the appropriate driver has been installed.

### 2.2.1 Windows 95/98 Installation

The Windows 95 drivers supplied with this card are compatible with installation and operation under Windows 98.

To install the card under Windows 95.

- 1 Turn on the PC and allow the operating system to discover new hardware. If a card of this type has already been installed on your system then the ports will automatically be installed as the next available COM port in your system. If not the system will discover New Hardware and prompt you to specify the device drivers to be used by the new device. When prompted for drivers select install from manufacturers disk supplied.
- 2 Insert the disk supplied with this product into the PC and browse the PCI247H<sup>2</sup>-9H<sup>2</sup> series driver. If the driver is supplied on floppy disk this will be in the route of the disk, otherwise it will be in an appropriate directory on the Amplicon Drivers CD.
- 3 When the drivers are installed the software will automatically install the hardware in the next available COM port address and available IRQ.
- 4 To configure and manage your ports you will need to use the device manager. To use device manager to configure your ports select Windows "" Start / Settings / Control Panel / System". Click the Device Manager tab and open "Ports (COM & LPT)". Amplicon PCI com ports are identified as "Amplicon PCI 24xH RS232 COM Port" or "Amplicon PCI 24xH RS485 COM Port" in the device list.
- 5 To change the default communications settings for a port, using Device Manager select the COM Port from the list, Click properties and Click the "Port Settings Tab". You will then be able to change the baud rate, number of data bits in a character, parity, stop bits and flow control and configure half or full duplex operation
- 6 To check that the installation is correct or to modify COM port address using Device Manager select the COM Ports from the list, Click properties and Click the "resources" Tab. This shows the settings the installation software has assigned. The IRQ is assigned by the plug and play OS and can not be changed. However the address settings can be changed as required to any available setting. If the address is assigned to one of the standard port addresses then port becomes a standard port, i.e. COM1, COM2 etc. Please refer to the card base address assignment tables later in this manual.

### 2.2.2 Windows NT Installation

All of the PCI247H<sup>2</sup>-9H<sup>2</sup> Series are Plug and Play and come complete with all the software to install and operate the card in any PCI version 2.1 compliant host PC running under Windows NT.

1. Install the supplied Windows NT 4.0 serial driver by running the setup program. If the driver is supplied on floppy this will be in the root of the drive. If it is supplied on the Amplicon Drivers CD you will need to browse for the appropriate directory.
2. Once software is installed, the serial resources will be automatically found by your operating system.
3. A control panel applet called "Amplicon (plug and play)" will have been installed in the Windows NT control panel. To open the control Panel Applet select Windows Start/Settings/Control Panel and double click the "Amplicon (plug and play)" icon.

4. To change the default communications settings for a port, select the port from in the list and press settings. You will then be able to change the baud rate, number of data bits in a character, parity, stop bits and flow control.
5. To configure half or full duplex operation or change the COM port number of the port, (COM1, COM2 etc), select the port from the list, press settings and then press advanced. As well as being able to select half-duplex mode and COM port number, you will also be able to review the assigned base address and IRQ for that port.

### **2.2.3 Windows 2000/XP Installation**

All of the PCI247H<sup>2</sup>-9H<sup>2</sup> Series are Plug and Play and come complete with all the software to install and operate the card in any PCI version 2.1 compliant host PC running under Windows 2000/XP.

To install the card under Windows 2000/XP.

1. Ensure the Amplicon drivers CD-ROM is in the CD drive.
2. When the system detects the new card, select "search for a suitable driver for my device".
3. When prompted for search locations tick "CD-ROM driver" and "Specify a Location"
4. If Windows fails to find the new card's .INF file automatically, browse to the root directory on the CD-ROM and click "OK". Alternatively, since the required software has already been extracted from the CD-ROM into the "C:\AMPLICON\SERIAL" directory, you may browse to that directory instead.
5. Windows should find a suitable file called PCI24xh.inf.
6. If Windows asks for a disk labelled "Amplicon Serial Device Driver Disk" when trying to copy files, click "OK" to cancel the alert box, then browse to the root directory on the CD-ROM and click on "OK". As before, the "C:\AMPLICON\SERIAL" directory may be used instead, assuming the required software has already been extracted from CD-ROM to that directory.
7. Windows may say that the driver has not been digitally signed, select YES to continue the installation.
8. Windows should correctly identify the card as an "Amplicon PCI24xH Serial Controller" (where "x" depends on the type of card). Click on the "Finish".
9. Windows will install the drivers for the new COM ports.
10. Windows may again say that the driver has not been digitally signed, select YES to continue the installation.
11. The COM ports can now be configured by following the procedure detailed below in "Configuring COM Ports".
12. If this is the first time you have installed the Amplicon card you will need to restart the computer.

## 2.2.4 Configuring COM Ports

If you need to change the resources assigned you can do this by following the instructions below:

1. Go to Control Panel and double click "System" then click on the "Hardware" tab, then click on the "Device Manager" button.
2. Double click on the "Ports" icon to show a list of available serial and parallel ports.
3. Ports that are using the Amplicon Serial Drivers will be labelled as follows:

Amplicon Hi-Speed RS232 Port	For high-speed RS-232 ports on PCI cards (e.g. PCI247H <sup>2</sup> ).
Amplicon Hi-Speed RS485 Port	For high-speed RS-485 ports on PCI cards (e.g. PCI248H <sup>2</sup> ).

Double click on an Amplicon COM port to bring up the properties sheet for that port

Default baud rate, flow control, half duplex mode and com port number can be changed on the "Port Settings" tab.

## 2.2.5 Linux Installation

For installation and configuration instructions please refer to the documentation contained in the Amplicon Serial Driver for Linux package on the Softman CD. The package contains the source code for two kernel modules: the Amplicon serial driver itself (ampser) and a module for handling shared interrupts on Amplicon ISA serial cards (isa\_global\_rearm). Only the former of these (ampser) is required for the PCI247-9H<sup>2</sup> cards.

## 2.3 Card Configuration

### 2.3.1 Configuration Jumper Settings

Most configuration settings on the PCI247H<sup>2</sup>-9H<sup>2</sup> are performed by the plug and play installation program. However the PCI248H<sup>2</sup> and PCI249H<sup>2</sup> have some jumpers and these need to be set before mounting this board in the host . The functions of the jumpers on the PCI247H<sup>2</sup>-9H<sup>2</sup> Series are confined to the RS-485 ports on the PCI248H<sup>2</sup>(I) and PCI249H<sup>2</sup>(I). They control the pin-out of the interface connector and whether or not the RS-485 port is terminated. The PCI247H<sup>2</sup> does not have jumpers.

### 2.3.2 Base Address Selection

Each channel discrete base address is set by the plug and play installation software.

### 2.3.3 Interrupt Level Selection (IRQ)

The interrupt signal from each channel can be assigned to any appropriate IRQ available in the PC. The assignment is dealt with at installation by Plug and Play installation software

The interrupt operations comply with the requirements laid down in the PCI Bus version 2.1 specification.

The interrupt request line, IRQ 3-5, IRQ7, IRQ10-12 or IRQ15, signals the host PC (Permanent Master) that the PCI247H<sup>2</sup>-9H<sup>2</sup> Series adapter requires service. The host PC processor acknowledges the interrupt and takes the required action with the appropriate service routine.

The PCI bus assigns PCI interrupts to PC IRQ levels and allows multiple PCI interrupts to share the same PC IRQ. The same IRQ level may be set for both channels and can be shared with other PCI247H<sup>2</sup>-9H<sup>2</sup> Series boards in the PC.

Careful checking of interrupt assignment in your system is recommended prior to card installation using the plug and play software. The operating system will inform of any contention when selecting an IRQ level during installation. The normal allocation of hardware interrupt levels is tabled below.

PCI247H <sup>2</sup> -9H <sup>2</sup> (i) Selected IRQ Level	Host PC IRQ Name	Host PC Interrupt Number (hex)	Host PC Description of Usage
—	IRQ 0	8	Timer
—	IRQ 1	9	Keyboard
—	IRQ 2	A	Int 8 - 15
<b>3</b>	IRQ 3	B	COM or SDLC
<b>4</b>	IRQ 4	C	COM or SDLC
<b>5</b>	IRQ 5	D	LPT2
—	IRQ 6	E	Floppy Disk
<b>7</b>	IRQ 7	F	LPT1
—	IRQ 8	70	Real Time Clock
—	IRQ 9	71	Re-directed to IRQ2
<b>10</b>	IRQ10	72	Unassigned
<b>11</b>	IRQ11	73	Unassigned
<b>12</b>	IRQ12	74	Unassigned (or PS2-mouse)
—	IRQ13	75	Co-processor
—	IRQ14	76	Hard Disk
<b>15</b>	IRQ15	77	Unassigned

#### 2.3.4 RS-485 Full Duplex / Half Duplex Operation

An RS-485 port on a PCI248H<sup>2</sup>(i) or PCI249H<sup>2</sup>(i) can be used in either full duplex (simultaneous transmission and reception over two independent wire pairs) or half duplex (sequential transmission or reception over a single wire pair).

In full duplex operation the transmitter can be left in its enabled state at all times. In half duplex receive operation, the transmitter must be disabled by switching to its high impedance state to allow reception of data over the same serial lines. This is done automatically by the software when half-duplex mode is selected. However The TxA line must be joined to the RxA' line and the TxB line must be joined to the RxB' line on the connector to provide the two wires of half-duplex operation.

Selection of full or half-duplex operation is performed under software control of the Windows drivers, through the Windows Control Panel. Refer to the installation guide for your operating system in Section 2.2

### 2.3.5 Transmission Line Termination

#### 2.3.5.1 Termination Resistors for RS-422/485 Receivers

Operation of RS-422/485 systems requires that the lines be terminated at the final receiver. The simplest termination is by a line-to-line resistor, and provision is made to connect this 120Ω terminator on the data and control inputs of each RS-422/485 channel. Correct termination is built into the RS-232 receivers.

The RS-422/485 CTS control line receivers are permanently terminated and the data input terminator resistors can be disconnected by removal of a jumper for each channel. Jumpers J62 and J82 are factory fitted, and should be retained in position as required to terminate the following differential receiver line pairs:-

RECEIVER	JUMPER
Channel 1 Rx Data Terminator	J62
Channel 2 Rx Data Terminator	J82

Further notes on RS-422 and RS-485 operation are given later in Chapter 4, 'Using the Serial Communications Boards'

#### 2.3.6 Jumper Factory Settings Summary

The PCI247H<sup>2</sup>-9H<sup>2</sup> Series boards can be reset to their factory defaults by re-configuring the board according to the following tables.

Jumper	Function	PCI247H <sup>2</sup> (i)	PCI248H <sup>2</sup> (i)	PCI249H <sup>2</sup> (i)
J62	Channel 1 Termination	N/A	In	N/A
J82	Channel 2 Termination	N/A	In	In
J63-71	Channel 1 Amplicon pinout	N/A	1-2	N/A
J83-91	Channel 2 Amplicon pinout	N/A	1-2	1-2

**FIGURE 2.1 FACTORY JUMPER SETTING SUMMARY**

### 2.4 Application Software

The 'HyperTerminal' program supplied with Windows is compatible with the PCI247H<sup>2</sup>-9H<sup>2</sup> Series boards and is useful for testing and operation on COM1 to COM4 channels.

The software supplied with this card supports operation with Windows 95, 98, ME, NT, 2000, XP, and Linux only.

The board will operate in conjunction all commercially available communications and data acquisition packages that support Windows serial ports.

Install the required application software in accordance with the vendor's instructions, assigning communications to the required COM port.

### 2.5 Installation Testing

Many applications packages include a self-test feature, and when the hardware and software have been satisfactorily installed, any such test should be performed to check correct operation.

If no self-test is available, or a problem occurs, see the later Section 4.4, 'Testing and Troubleshooting'.

**3 MAKING THE CONNECTIONS**

This chapter describes the signal and control connections that the user must make between the PCI247H<sup>2</sup>-9H<sup>2</sup> Series board and any external serial communications devices. These input/output connections are made through the D type plugs protruding from the PC adapter slot corresponding to the chosen board position.

**3.1 External Connections**

Connections to the RS-232 and/or RS-422/485 lines are made via 9 pin D type connectors on the rear panel. The on-board connectors are male and the mating sockets are available as accessories. Provision is made for securing by screw jacks. Each channel has its individual connector, located as shown in Figure 3.4 and assigned as follows:-

	<b>Channel 1 (Upper)</b>	<b>Channel 2 (Lower)</b>
PCI247H <sup>2</sup> (i)	PL60-9 way RS-232	PL80-9 way RS-232
PCI248H <sup>2</sup> (i)	PL60-9 way RS-422/485	PL80-9 way RS-422/485
PCI249H <sup>2</sup> (i)	PL60-9 way RS-232	PL80-9 way RS-422/485

The non-isolated 9 way RS-232 ports conform to industry standard pinouts, and will support commercially available cables and adapters.

**3.2 RS-232 9 way Port**

The 9 pin D connector is fitted to the upper (PL60) and lower (PL-80) RS-232 port of the PCI247H<sup>2</sup>(i) and the pin-out conforms to the industry standard.

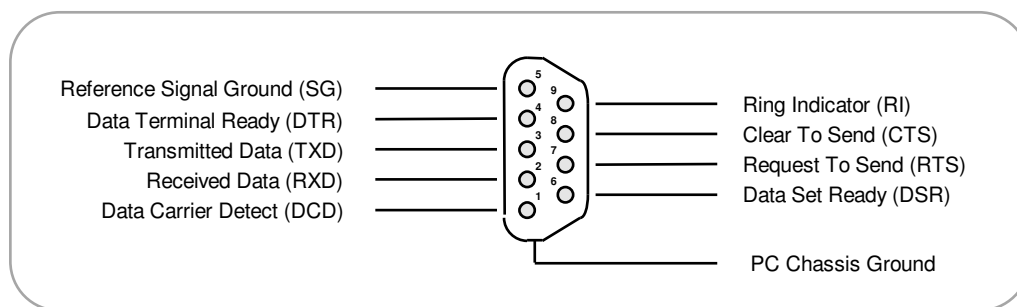

**FIGURE 3.1 RS-232 9 WAY PORT PIN DESIGNATIONS**

**3.3 RS-422/485 9 way Port**

This 9 pin D connector is fitted to the upper (PL-60) and lower (PL-80) RS-422/485 port of the PCI248H<sup>2</sup>(i) and the lower (PL-80) RS-422/485 port of the PCI249H<sup>2</sup>(i).

Two pin assignment options are available for the 9 way RS-485 connector. These are selectable by means of jumper links J63-71 for channel 1 and links J83-91 for channel 2.

**3.3.1 RS-422/485 9 way Port Amplicon pin assignment**

This is the factory set default pinout compatible with the PC248/PC249(i) series cards. To select this pinout J63-71 for channel 1 and J83-91 for channel 2 should be set in positions 1-2, as shown below.

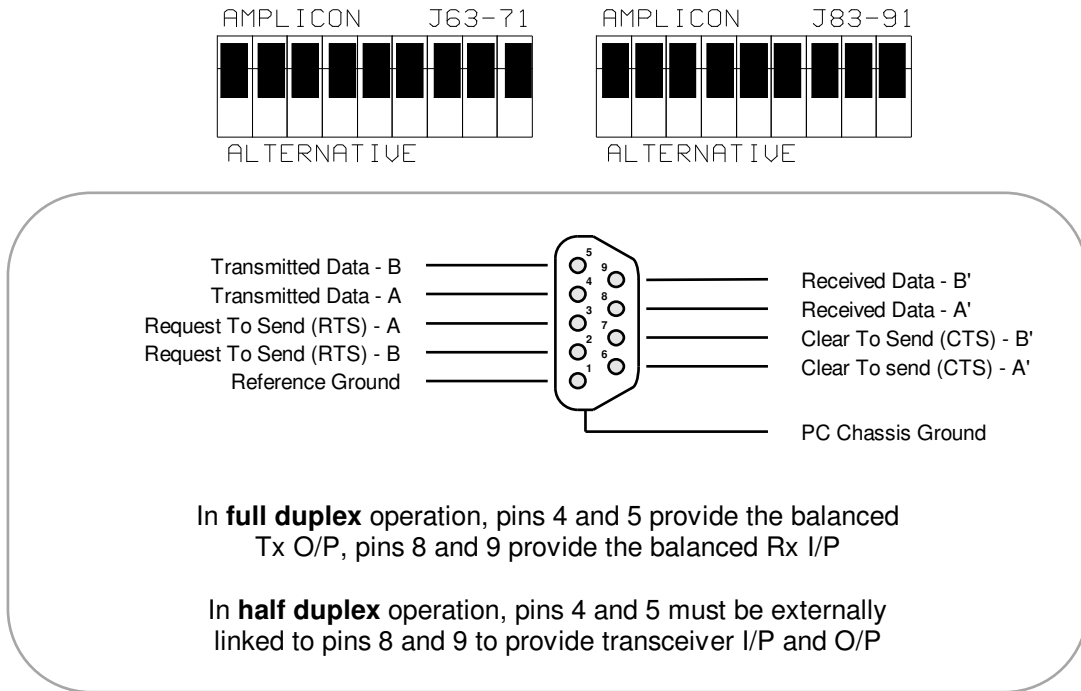

**FIGURE 3.2 RS-422/485 AMPLICON STANDARD PORT PIN DESIGNATIONS**

**3.3.2 RS-422/485 9 way Port Alternative pin assignment**

This is the alternative pinout compatible with the Moxa Rocketport series of cards. To select this pinout J63-71 for channel 1 and J83-91 for channel 2 should be set in positions 2-3, as shown below.

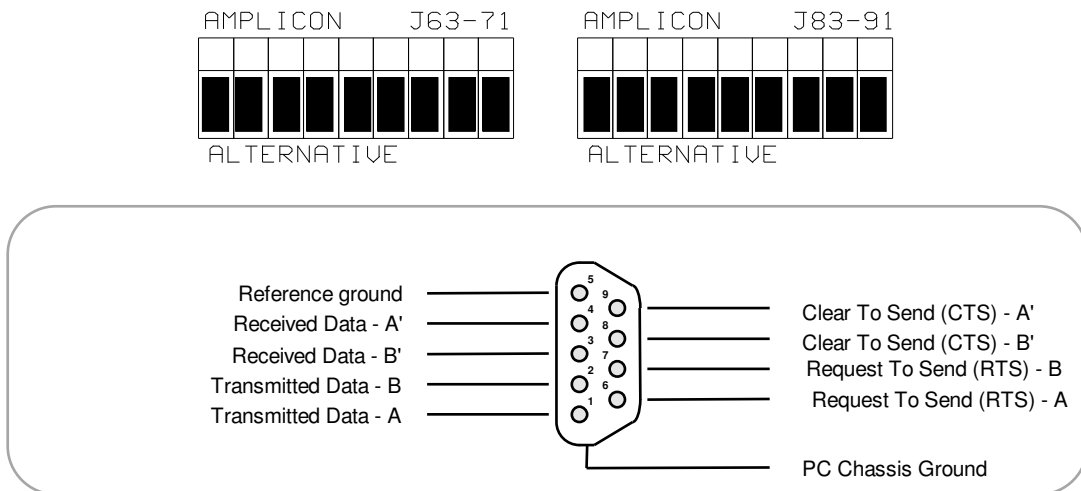
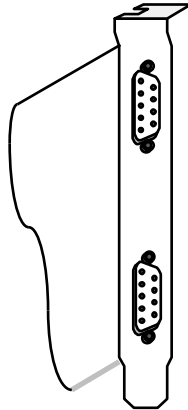

**FIGURE 3.3 RS-422/485 ALTERNATIVE STANDARD PORT PIN DESIGNATIONS**

### 3.4 Input/Output Connector Locations

The two serial channel input/output connectors are mounted on the panel and the positions of the two connectors for the various board types are shown in Figure 3.4 below.

#### PCI247H<sup>2</sup>(i)



**Upper Connector PL-60**  
**Channel 1**  
**9 pin RS-232**  
**Pin-outs shown in Figure 3.1**

**Lower Connector PL-80**  
**Channel 2**  
**9 pin RS-232**  
**Pin-outs shown in Figure 3.1**

#### PCI248H<sup>2</sup>(i)

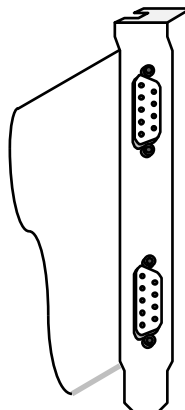

**Upper Connector PL-60**  
**Channel 1**  
**9 pin RS-422/485**  
**Pin-outs shown in Figure 3.2/3**

**Lower Connector PL-80**  
**Channel 2**  
**9 pin RS-422/485**  
**Pin-outs shown in Figure 3.2/3**

#### PCI249H<sup>2</sup>(i)

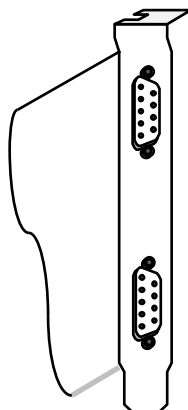

**Upper Connector PL-60**  
**Channel 1**  
**9 pin RS-232**  
**Pin-outs shown in Figure 3.1**

**Lower Connector PL-80**  
**Channel 2**  
**9 pin RS-422/485**  
**Pin-outs shown in Figure 3.2/3**

**FIGURE 3.4 INPUT/OUTPUT CONNECTOR LOCATIONS FOR ALL BOARD TYPES**

### 3.5 Connector Wiring for RS-422/485 Full/Half Duplex

In the full duplex position, the serial RS-422/485 data signals are transmitted on the wire pair Tx-A (pin 4) and Tx-B (pin 5) and the incoming signals are received on Rx-A' (pin 8) and Rx-B' (pin 9). In half duplex RS-485 operation, the data signals are both transmitted and received on the two pairs externally wired in parallel. See Figure 3.5 for the connector wiring to provide full duplex or half-duplex operation.

The flow control signals, Request To Send (RTS) and Clear To Send (CTS) are also available on the connector, and will be required for use in some full duplex applications. If these control signals are not required for connection to the device at the other end of the link, the signals may be looped back as shown dotted in the diagram. Looping in this way allows the RTS signal to be monitored, which is a requirement of some programs.

**THIS DIAGRAM REFERS TO THE AMPLICON STANDARD PINOUT. FOR ALTERNATIVE PIN ASSIGNMENTS REFER TO FIGURE 3.3**

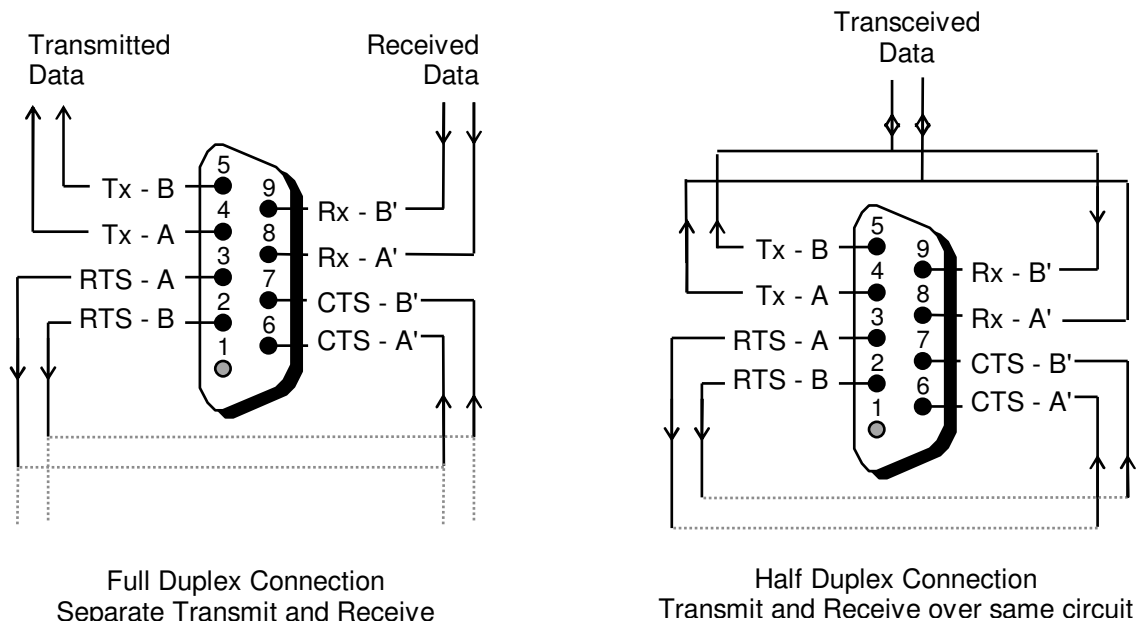

**FIGURE 3.5 CONNECTIONS FOR FULL AND HALF DUPLEX OPERATION**

### 3.6 The Ground Connections

Each connector is equipped with two or more different ground connections and care must be taken in the use of these grounds and the cable design to ensure that the EMC requirements are met, and that isolation integrity is maintained in the case of the boards with isolated input/output.

The connector pin-out is such that commercially available cables and adapters are normally usable without modification, but the user must be aware of the requirements to maintain isolation when the devices at each end are not at nominal earth potential. The choice of proper, screened cables is also important for the system to maintain Electro-Magnetic Compatibility.

### 3.6.1 Ground Connections for Non-isolated Boards

For the PCI247/8/9H<sup>2</sup> **non-isolated** boards, the ground connections are normal for a serial interface and remain compatible with the earlier PC47/8/9AT range of boards. The various ground connections are:-

#### RS-232 Ground Connections

**Reference Signal Ground** (pin 5) is internally connected to the PC signal ground and should be externally connected to the Signal Ground pin of the RS-232 device at the other end of the link.

The **Connector Shell** is internally connected to the PC chassis ground. To maintain shield integrity, metal connector hoods should be used, preferably at both ends. These hoods make contact with the connector shell and the cable screen so maintaining an overall shield.

#### RS-422/485 Ground Connections

**Reference Ground** is internally connected to the PC signal ground that is not normally required for the differential operation of RS-422/485 line pairs. This pin may be left unconnected.

**Connector Shell** is internally connected to the PC chassis ground. To maintain shield integrity, metal connector hoods should be used, preferably at both ends. These hoods make contact with the connector shell and the cable screen so maintaining an overall shield.

### 3.6.2 Ground Connections for Isolated Boards

For the PCI247H<sup>2</sup>i-9H<sup>2</sup>i boards with **isolated** input/output, the various ground connections are:-

#### RS-232 Ground Connections

**Reference Signal Ground** (Pin 5) is internally connected to the isolated ground circuit and should be externally connected to the Signal Ground pin of the RS-232 device at the other end of the link. Any voltage appearing between this reference ground and the host PC ground is common mode and must not exceed 250 V peak. The internal resistance between these grounds is 1 M $\Omega$ .

**Connector Shell** is internally connected to the PC chassis ground. To maintain shield integrity, a metal connector hood should be used which must be connected to the cable screen at the host PC end. If the remote device is specifically at an elevated potential, then connecting the cable screen, and hence the chassis grounds, at both ends could void the isolation. It is therefore the best and safest practice to connect the cable screen at the host PC end only.

See Figure 3.6 for an example of 9 pin isolated RS-232 connections to another DTE device. A 25-pin circuit follows the same practice.

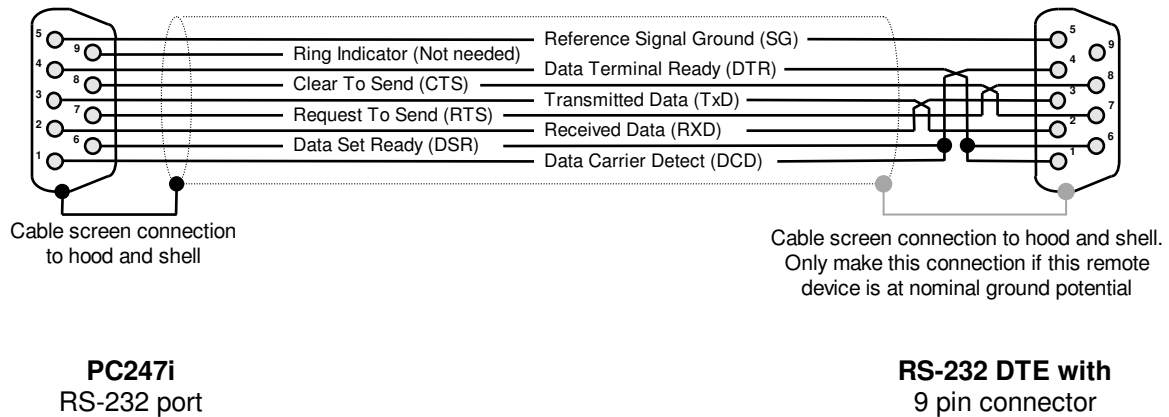

**FIGURE 3.6 9 PIN ISOLATED RS-232 CONNECTIONS TO ANOTHER DTE DEVICE**

**RS-422/485 Ground Connections**

**Reference Ground** is internally connected to the isolated signal ground that must be connected to the signal ground of the remote RS-422/485 device. Any voltage appearing between this reference ground and the host PC ground is common mode and must not exceed 250 V peak. The internal resistance between these grounds is 1 MΩ.

**Connector Shell** is internally connected to the PC chassis ground. To maintain shield integrity, a metal connector hood should be used which must be connected to the cable screen at the host PC end. If the remote device is specifically at an elevated potential, then connecting the cable screen, and hence the chassis grounds, at both ends could void the isolation. It is therefore the best and safest practice to connect the cable screen only at the host PC end.

**3.7 Choice of Cable**

As speeds and distances of communication increase the choice of cable over which the communication is to take place becomes critical.

Amplicon recommend Belden Cable, part no. 8132 for use in long distance high speed RS-422 & RS-485 networks. This is multi-shielded twisted pair cable. It has a capacitance of 20pF/m and characteristic impedance of 120 ohms.

In order to maintain compliance with the EMC directive, 89/336/EEC, it is mandatory that the final system integrator uses good quality screened cables for external connections. It is up to the final system integrator to ensure that compliance with the Directive is maintained. Please contact our sales staff for further information.

## 4 USING THE SERIAL COMMUNICATIONS BOARDS

### 4.1 Why Isolate?

The PCI247H<sup>2</sup><sub>i</sub>, PCI248H<sup>2</sup><sub>i</sub> and PCI249H<sup>2</sup><sub>i</sub> provide complete electrical isolation between any signals connected to a serial port, signals connected to the other port and the circuits of the host computer. In a compact office or laboratory environment such isolation may not be necessary, however in a wide-field industrial situation, serial digital communication can be disrupted by many types of contaminating signals, most of which can be eliminated by the proper use of isolation.

Both digital input receivers and output drivers make use of opto-couplers to provide a signal path between external and internal circuits without any electrical connection being made. An opto-coupler comprises a Light Emitting Diode (LED) which is turned on by the incoming signal, and a photo-detector that receives the light and converts it into an electrical signal. The emitter and detector are mounted in a package that provides a light path together with high voltage insulation between the two sides. Power to the input/output circuits is provided by an isolated DC-DC converter, one for each channel.

Interfering signals can come from a variety of sources and are often greater in amplitude than the desired signal. Such an interfering signal is 'common mode' and is effectively the potential difference between the zero-signal reference points of the signal source and receiver. By using the PCI247H<sup>2</sup><sub>i</sub>-9H<sup>2</sup><sub>i</sub> isolated input and output boards, this potential difference appears across the isolation barrier and not in series with the signal as would be the case if direct connection was employed.



**DANGER**  
High Voltage

#### **BE AWARE**

#### **DANGER OF ELECTRIC SHOCK**

When the PCI247H<sup>2</sup><sub>i</sub>, PCI248H<sup>2</sup><sub>i</sub> or PCI249H<sup>2</sup><sub>i</sub> isolated board is in use in an open computer chassis, high voltages may be exposed on the connector and associated circuitry.

The two ends of a link would normally have their grounds connected together through the signal ground line, the protective ground line and/or the cable shield. Such a connection has an impedance such that an interfering signal caused by a difference in ground potentials is likely to be a few volts in amplitude, maybe peaking to tens of volts. However there may be circumstances or fault conditions in which higher common mode voltages exist, and the circuits of the PCI247H<sup>2</sup><sub>i</sub>-9H<sup>2</sup><sub>i</sub> are designed to hold off peak common mode voltages up to 250V.

RS-232 standards allow a transition region of  $\pm 3.0$  V, and within this region, signal variations will not be detected. If the signal (real or noise) is  $< -3.0$  V, it will be detected as a mark for a data line or OFF for a control line. If the signal is  $> +3.0$  V, it will be detected as a space for data or ON for a control signal.

**In RS-232 operations, any ground offset, noise, hum or other interference exceeding  $\pm 3.0$  V peak amplitude will be detected as a real signal and corrupt the data or control functions.**

RS-422 and RS-485 standards provide a better level of ground noise immunity than RS-232, the maximum common mode voltages being  $-7.0$  V to  $+7.0$  V and  $-7.0$  V to  $+12.0$  V respectively for the two standards. **However, any ground offset, noise, hum or other interference exceeding these peak amplitudes will be detected as real signals and may corrupt the data or control functions.**

Breaking the common ground connection by the use of the PCI247H<sup>2</sup>i-9H<sup>2</sup>i isolated interface completely eliminates the detection of these interfering signals as real signals with no loss or corruption of data.

In general, isolation is only required at one end of a data link, and Figure 4.1 illustrates the principle of the isolated interface and shows how the signal loop is self-contained and not subject to common mode interference.

Multi-drop or broadcast systems with many RS-485 or RS-422 nodes on a single circuit may require all circuits to be isolated for error free serial data communication.

The pinouts of the isolated PCI247H<sup>2</sup>i-9H<sup>2</sup>i are configured so that the user may plug in standard cables and in many cases need not be concerned about making any changes to effect full isolation. If the cable is screened, with the screen connected to the D type shell and/or cover at one end, the overall screening will be maintained, together with proper implementation of the isolation.

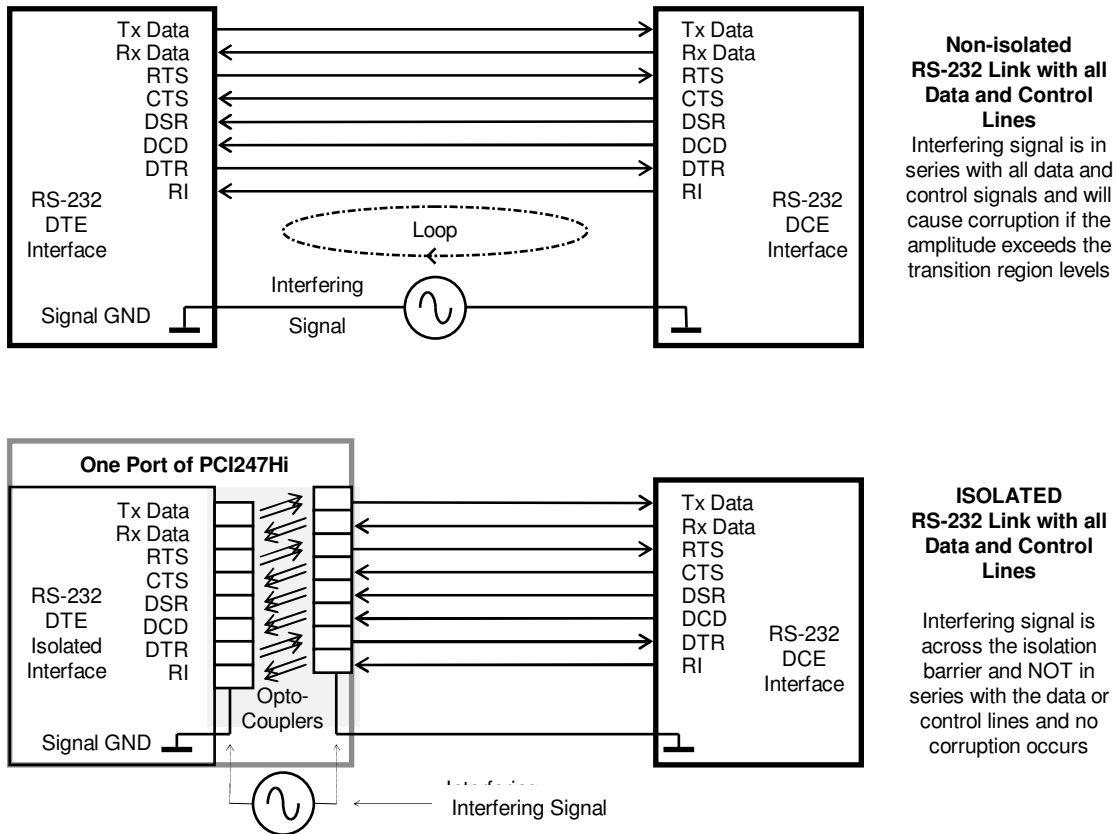

**FIGURE 4.1 ELIMINATION OF INTERFERING SIGNALS BY ISOLATION**

## 4.2 Application Notes

As previously noted, many applications packages are designed to support data transfer over the standard serial communications ports. When set up as specified, and conventional multi-way cables and connectors are in use, then the interface will be transparent to the user. However, for special applications, particularly when use of the RS-485 interface is required, the following notes will be helpful.

### 4.2.1 Applicable Standards

The prefix 'RS' signifies Recommended Standard, and the three interface types, RS-232, RS-422 and RS-485, supported by the Amplicon range of boards are all well defined in the appropriate standards publications. The functions and features of the data and control interfaces presented by the PCI247H<sup>2</sup>-9H<sup>2</sup> Series generally conform to normal industry practice employing a subset of the full standards.

The RS-232 serial interface standard is now at revision E and its full title is EAI/TIA RS-232-E, *"Interface Between Data Terminal Equipment and Data Communication Equipment Employing Serial Binary Data Interchange"*. Similar European standards CCITT V.24 and V.28 define an interface which is operationally compatible with RS-232.

The RS-232 ports of the PCI247H<sup>2</sup> and PCI249H<sup>2</sup> are designated as DTE (Data Terminal Equipment) in accordance with normal practice for a computer driven serial port. The current RS-232 standard specifies the 25 way male D type connector for DTE. Earlier revisions of the RS-232 standard did not specify the connector type.

The full 25 lines are not required to support the common functions of RS-232, and IBM and other manufacturers frequently adopt a 9 way D type connector that provides all the necessary functionality. Where this 9-wire system is used, manufacturers conform to interface standard EIA 574, with the pin-out configuration as shown in Figure 3.2, the channel 2 port of the PCI247H<sup>2</sup>(i).

The RS-422 interface is defined in the EIA/TIA standard RS-422-B, *"Electrical Characteristics of Balanced Voltage Digital Interface Circuits"*. As stated, this standard defines the electrical characteristics but does not specify a connector type or pin-out configuration. The PCI248H<sup>2</sup>(i) and PCI249H<sup>2</sup>(i) fully meet the RS-422 standard specification with communication via a 9 pin D type connector wired as shown in Figure 3.3 or 3.4.

The RS-485 specification is also published as EIA standard EIA 530 pt 87 and is closely allied to the RS-422 standard. The PCI248H<sup>2</sup>(i) and PCI249H<sup>2</sup>(i) meet the requirements laid down in the RS-485 standard.

### 4.2.2 RS-232 Application Notes

RS-232 was approved as a standard interface in 1969. Before and since that time this interface in its various revisions has been very popular despite its many shortcomings and usage outside its intended role. Most small computers now have an RS-232 interface as standard, or easily added, and many peripherals and instruments support this serial interface, but not all in the same way. Hence the application of an RS-232 connection needs careful study of the equipment manufacturers connections and methods before the devices are linked. However RS-232 lines are quite safe if wrongly connected, so the experimental use of a break-out box or 'hit and miss' methods of establishing communication are often employed.

#### 4.2.2.1 Electrical Levels

When testing serial communications circuits, it is useful to know what signal levels to expect. The specified voltage levels of RS-232 data and control signals are summarised in the following table:-

Interchange Voltage	-15 to -3 V	+3 to +15 V
Data Binary State	1	0
Data Signal	Marking	Spacing
Control Function (RTS, DTR)	OFF	ON

The levels are specified relative to signal ground at 0 volts, (the remote device signal ground in the case of isolated ports), and the region between -3 and +3 volts is the transition region. The voltage levels transmitted by the PCI247H<sup>2</sup>(i) and PCI249H<sup>2</sup>(i) data and control lines are about  $\pm 10$  V.

#### 4.2.2.2 Data Rates and Cable lengths

The RS-232 standard specifies the data signalling rate up to 20 kilobaud, but an RS-232 interface is often used up to 1 MBd. The specified electrical characteristics allow a typical maximum cable length between transmitter and associated receiver of about 15 m (50 ft). In practice, cable lengths can often be increased at lower rates and may need to be kept shorter at rates above 20 kBd.

RS-422 and RS-485 standards specify data signalling rates up to 10 MBd, with decreasing cable length maxima at the higher rates. At the maximum signalling rate of the PCI247H<sup>2</sup>-9H<sup>2</sup> Series (1 MBd), the maximum cable length is specified as 100 m.

#### 4.2.2.3 RS-232 Cable Adapters

Various plug-in adapter and test modules are available from **Amplicon Liveline Ltd** to ease the problems of interconnecting RS-232 interfaces. See [www.amplicon.co.uk](http://www.amplicon.co.uk) or the current catalogue for full details and descriptions.

### 4.3 RS-422/485 Application Notes

RS-422 and RS-485 have very similar characteristics, with RS-485 being compatible with, and offering all the advantages of RS-422 plus the additional capability of multi-transmitter operation, higher device capacity and better common mode performance. RS-422 pre-dated RS-485 as a standard, but RS-485 is now more popular and used in new system design.

For the PCI248H<sup>2</sup>(i) and PCI249H<sup>2</sup>(i), the on board circuitry for the two modes is identical, the application deciding the mode of interface operation.

#### 4.3.1 RS-422/485 Parameters

The following table summarises the principal parameters of the RS-422-B and RS-485 standards, and shows RS-232-E for comparison. The actual driver/receiver devices used in the PCI247H<sup>2</sup>-9H<sup>2</sup> Series at least meet these specifications, and provide superior performance in some cases.

EIA STANDARD	RS-232-E	RS-422-B	RS-485
Mode of Operation	Single ended	Differential	Differential
Number of Drivers and Receivers on line	1 Driver 1 Receiver	1 Driver 10 Receivers	32 Drivers 32 Receivers
Max. Cable Length	15 m	1200 m	1200 m
Max. Data Rate	20 kBd	10 MBd	10 MBd
Max. Common Mode	N/A	+7 V, -7 V	+12 V, -7 V
Driver Voltage	$\pm 5$ V to $\pm 15$ V	$\pm 2$ V min	$\pm 1.5$ V min
Driver Load	3 k $\Omega$ to 7 k $\Omega$	100 $\Omega$ min	60 $\Omega$ min
Driver Slew rate	30 V/ $\mu$ s	N/A	N/A
Driver Output Short Circuit Limit	500 mA to Vcc or Ground	150 mA to Ground	150 mA to Gnd 250 mA to Vcc
Receiver Input Resistance	3 k $\Omega$ to 7 k $\Omega$	4 k $\Omega$	12 k $\Omega$
Receiver Sensitivity	$\pm 3$ V	$\pm 200$ mV	$\pm 200$ mV
Receiver Hysteresis	1.15 V	50 mV	50 mV

FIGURE 4.2 COMMUNICATIONS STANDARDS SUMMARY

#### 4.3.2 RS-422/485 Signaling Sense

The RS-422 and RS-485 standards define the polarity of the signalling lines as follows.

"The signalling sense of the voltages appearing across the interconnecting cable is defined as follows:

- a. The A terminal of the generator shall be negative with respect to the B terminal for a binary 1 (MARK or OFF) state
- b. The A terminal of the generator shall be positive with respect to the B terminal for a binary 0 (SPACE or ON) state"

#### 4.3.3 RS-422/485 Multi-drop Applications

RS-422 can provide limited multi-drop capability, using two twisted wire pairs in a broadcast mode. One wire pair connects one transmitter to multiple receivers, but if duplex operation is required, only one receiving station can answer back. FIGURE 4.3 shows a typical RS-422 broadcast mode configuration with terminator resistors at the end receivers.

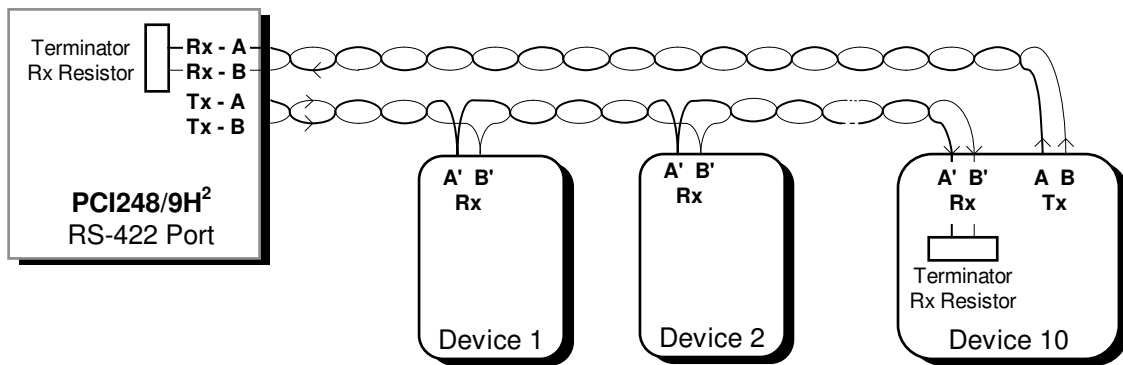

**FIGURE 4.3 RS-422 CONNECTED IN BROADCAST MODE**

RS-485 allows multiple (up to 32) unit loads to be connected in half duplex on a single twisted wire pair for 'party line' type of communications as illustrated in FIGURE 4.4. A method must be used to stop more than one transmitter being on the line at any time, ensuring that all other transmitters are in a high impedance state, although the circuit design is such that no damage will be done to the transceivers if several transmitters are turned on together.

See chapter 5.3.7, 'Half Duplex Transmission Turnaround' for a discussion of the programming required for controlling the transmission direction.

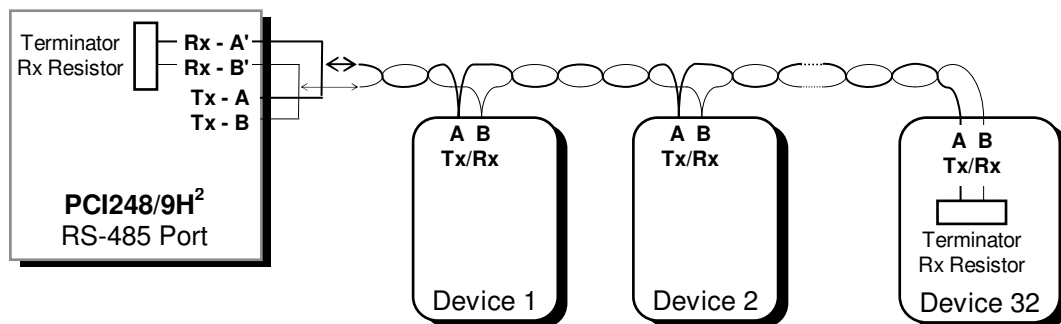

**FIGURE 4.4 RS-485 CONNECTED IN MULTI-DROP, HALF DUPLEX MODE**

#### 4.3.4 RS-422/485 Bus Termination

For proper operation of the RS-422/485 bus in full or half duplex, multi-drop or point to point communication, it is recommended that termination be applied to the receiver end of the data and control lines.

The simplest form of termination is line to line with typically a 120 Ω across the differential input, and this terminator is available on the PCI248H<sup>2</sup>(i) and PCI249H<sup>2</sup>(i) boards, selectable by jumpers J62 for channel 1 and J82 for channel 2 as appropriate.

In a multi-drop system, the terminator resistor is only required at the device receiver located at the far end of the cable. If this is in half duplex operation, then both ends of the bus cable are equipped with receivers (transceivers) so termination is necessary at both ends. RS-485 transmitter circuits are capable of driving a minimum load resistance of 60 Ω, so no more than two terminator resistors should be connected to any one bus.

#### 4.3.5 Cabling of RS-422/485 Bus

The RS-422/485 employs a differential method of signal transmission, and each bus cable has to be a wire pair, preferably twisted and screened to keep induced and radiated noise to a minimum. The bus distribution cable is effectively a transmission line, and appropriate techniques should be used for installation of the cables. In a multi-drop environment, the cable should be 'looped through' each device, or if a spur is necessary, the spur length should be kept to a minimum.

Maximum end-to-end cable length and the communication baud rate are not mutually exclusive. **Typical** maximum transmission rates versus cable lengths are shown in the following table. The data rates applicable to the PCI248H<sup>2</sup>(i)/PCI249H<sup>2</sup>(i) are shown in bold type.

<u>Transmission Rate</u>	<u>Maximum Distance</u>
Up to 100 kBd	1200 m
<b>115.3 kBd</b>	<b>1000 m</b>
<b>1000 kBd</b>	<b>100 m</b>
<b>10000 kBd</b>	<b>10 m</b>

If screened cable is used, some thought must be given to the connection of the screen (shield). This screen should not normally be used as a ground return for non-isolated devices and it is safest to only connect the screen at a single point to the ground of one device.

The voltage between the grounds of the various devices must not cause the common mode voltage rating of any device on the bus to be exceeded. The isolated versions, PCI248H<sup>2</sup>i or PCI249H<sup>2</sup>i must be used and the allowable common mode voltage range is considerably increased.

If the installation instructions have been correctly followed, and the serial communications card is being used in conjunction with a proven software driver, then it is unlikely that any problems will be experienced in establishing communications through the serial interface.

When difficulties do occur, the following notes may be helpful in isolating the problem area.

#### 4.4 Testing and Troubleshooting

The two channels of each board in the PCI247H<sup>2</sup>-9H<sup>2</sup>(i) Series are independent, and testing of each channel can be undertaken separately. Ensure that **each channel** has installed correctly and that the wiring to the connector is correct before commencing the tests.

##### 4.4.1 Testing with the Application Software

If either channel 1 or 2 appears to be working properly in the communication circuit and the other channel fails, then in many cases the two channels can be interchanged.

After interchanging channels, if the same channel (1 or 2) fails, then the problem is on the board and service is necessary, and should be returned to Amplicon. See Section 1.7 for details.

If, after interchanging channels, the other channel of 1 or 2 fails, then the problem is outside the board, and the following areas should be investigated.

PC Bus contention. Ensure that register addresses or non-shareable IRQ levels do not clash with other board or in-built components of the host PC. If necessary inhibit any COMs channels that are built into the baseboard or multi-function plug-in boards. Running TEST\_COM (see 4.4.2.1) in a 'clean dos mode', will automatically detect and test any Amplicon PCI Serial Communication cards. Clean Dos Mode allows the card to be tested prior to any device drivers requesting base addresses and interrupts. However system devices in the BIOS will still take interrupts and should be removed if problems still exist.

Communication circuits. For a communications circuit to operate correctly, both ends of the circuit, and the interconnecting cables must be serviceable and the correct connections made. The vagaries of RS-232 implementation often cause problems in making the proper connections, and the manufacturers instructions for the equipment at each end should be carefully checked.

Hardware handshaking control signals. If the communication is operating under a software handshaking protocol (X-ON, X-OFF etc.) then only the transmitted and received data lines need to be connected. If the application requires hardware handshaking by the use of control lines CTS, RTS, DSR, DTR or DCD, then these must be correctly interconnected or looped back, otherwise the program is likely to hang.

Polarity of RS-422/485 differential data lines. Not all suppliers use the same convention for the polarity of the differential data lines. The PCI248H<sup>2</sup>(i)/249H<sup>2</sup>(i) lines are labelled A and B for the transmitter and A' and B' for the receiver as defined in the RS-422/485 specification. If the other device is labelled differently, then:-

**A** is normally connected to **A** or **A'** or **Y** or **High** or **+**  
**B** is normally connected to **B** or **B'** or **Z** or **Low** or **-**

If all devices are not so labelled and the polarity is not evident, or if a problem is suspected in this area, then some experimentation may be necessary. No damage should be done to the interface hardware by reversing polarity.

#### **4.4.2 Testing Using the Supplied Software**

A test program is provided on the distribution diskette and this program allows operation of one channel of the board when the appropriate I/O connector is externally wired for loop back. In this diagnostic mode, data transmitted are immediately received on the same channel in full duplex operation. This allows the processor to verify the addressing, interrupt selection and the transmit and receive data paths of the selected serial channel.

##### **4.4.2.1 The Loop Back Connections**

The required channel of the PCI247/8/9H<sup>2</sup> Series board can be separated from external influences such as the signal cables, other devices and the applications program by performing a loop-back test. For both RS-232 and RS-422/485 tests, it is necessary to make up a wrap connector using a 9 or 25 way D type free socket that mates with the port under test. Then run a terminal emulator such as Hyper-terminal. See 4.4.2.2

FIGURE 4.5 shows the 9 way D connectors wired for full RS-232 loop back testing. No connections need to be made to the ground pins, and the connections to be made are summarised as follows:

Signal Function		9 Way	
From	To	Pin	Pin
TxD	RxD	3	2
RTS	CTS	7	8
DTR	DSR and DCD	4	6 and 1

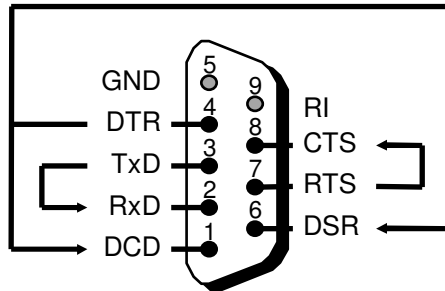

**FIGURE 4.5 RS-232 9 WAY LOOP-BACK TEST CONNECTIONS**

FIGURE 4.6 shows a 9 way D connector wired for full RS-422/485 loop back testing. The connections to be made are summarised in the following table. No connection needs to be made to the ground pin.

Signal Function		9 Way Amplicon		9 Way Alternative		78 Way (Chan 1)	
From	To	Pin	Pin	Pin	Pin	Pin	Pin
Tx-A	Rx-A'	4	8	1	4	41	22
Tx-B	Rx-B'	5	9	2	3	60	2
RTS-A	CTS-A'	3	6	6	9	61	23
RTS-B	CTS-B'	2	7	7	8	42	3

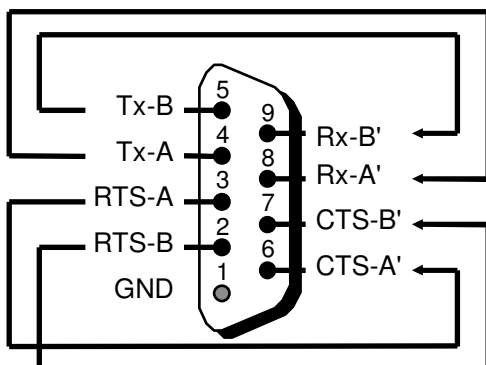

THIS DIAGRAM REFERS TO THE AMPLICON STANDARD PINOUT (FIG 3.3). FOR ALTERNATIVE PIN ASSIGNMENTS REFER TO FIGURE 3.4

**FIGURE 4.6 RS-422/485 LOOP-BACK TEST CONNECTIONS**

Loop-back testing is only appropriate to full duplex operation of the RS-422/485 ports.

#### 4.4.2.2 Loading and Using TEST\_COM

Note:- that this program does not work under NT. Use Hyper-Terminal instead of TEST\_COM, see 4.4.2.3

To use the supplied loop test program, first install the board and plug in the appropriate loop back connector into the port.

Open a DOS Window and load the test program by logging onto the drive or directory containing the program and typing TEST\_COM <return>. The program will load and the following screen will be displayed:

```
AMPLICON LIVELINE 200 Series Loopback Test Program
-----

Number of Amplicon Serial cards installed = 1

          1 = PCI248H CH1
          2 =           CH2

          Enter Number to Test
```

Enter the same hex number for the base address that is set up on the corresponding channel of the board. This must be a valid address in the range 000 to 7F8 <return>. A non-valid entry will request re-entry of the address. The program will now request:

```
Enter Channel Interrupt Level :
```

Enter the same number for the IRQ level that is set up on the corresponding channel of the board. This must be a valid value in the series 3, 4, 5, 7, 10, 11, 12 or 15 <return>. A non-valid entry will request re-entry of the interrupt level. The program will now request:

```
Enter Channel Baud Rate :
  1.      1.2kBd
  2.      9.6kBd
  3.     19.2kBd
  4.     112kBd (115.2)
(1 - 4) :
```

Enter 1 to 4 to select the rate required for the test. If everything is correct, the program will run and display:

```
AMPLICON LIVELINE 200 Series Loopback Test Program
-----
```

```
xxx : 
```

where xxx is the selected base address and Y is a constantly changing ASCII character testing all normal code combinations.

If there is a mismatch in the settings, or enough testing has been completed, the message:

```
Press a key to quit :
```

followed by:

Press SPACEBAR to repeat, any other key to quit

This allows the parameters to be re-entered. A mismatch of transmitted and received data causes a 'bleep' to be sounded, and although the program continues, the test should be terminated by pressing any key.

The other channel of the board may now be tested in the same way.

#### **4.4.2.3 Loop-back Testing Using A Terminal Emulator**

Windows 95, 98, ME, NT, 2000, and XP come supplied as standard with a Terminal Emulation package called Hyper Terminal. This can be used for simple loop-back testing and is found in the Accessories section from the START button.

The functionality of Hyper Terminal in Windows NT4 can access up to COM256 if it is installed.

Start Hyper-terminal and when prompted, enter a meaningful name such as Port 2 for COM2 or Port 4 for COM4 etc. The software will not let you use COM2 etc, as these are reserved words.

At the 'Connect to' dialogue box, select 'Direct to COM n', where 'n' is the number of the COM port using the list box 'Connect using'. Then click 'OK'.

Modify the port settings to your requirement if required, then click 'OK'. This will bring you to the main window and flashing cursor.

Now, key presses will be echoed to the screen when the board and the loop-back connection is correctly made.

## 5 PROGRAMMING

The PCI247H<sup>2</sup>-9H<sup>2</sup> Series are supplied with Windows 95, 98, ME, NT, 2000, and XP specific drivers. The Windows 95 driver is also compatible with Windows 98. Programming for use under other operating systems is beyond the scope of this manual.

### 5.1 Programming with Windows Device drivers

The distribution software provided with the PCI247H<sup>2</sup>-9H<sup>2</sup> Series board contains the Windows 95, 98, ME, NT, 2000, and XP device drivers.

Application programmers writing programs to run under these operating systems will simply treat the port as a standard COMs port. All Programs written to run under these operating systems will be able to use the advanced features of the card.

The special features such as 'High Data Rate', '128 Character FIFO' and 'Special Half Duplex mode (for RS-485 ports)' are decided at installation and from then on controlled by the device driver.

#### 5.1.1 Half Duplex Transmission Turnaround

In a multiple RS-485 transmitter installation, the application program controls the data communication turnaround and the selection of the bus 'talker'. Two common ways of providing program control are the 'Master/Slave' and 'Token Ring' methods. The 'Master/Slave' method designates one device on the network as Master, and this device supervises all transmissions by communicating with each of the Slaves in turn and offering it a transmission slot. In token ring operation, each device knows its ID neighbour and only talks directly to this next device. Thus communication only occurs between adjacent pairs of devices and this makes for a flexible network but can be a more difficult method to implement.

In half duplex mode the RS-485 transmit buffer is enabled automatically, by the 16C950 UART, whenever data is waiting to be sent in the UART Transmit buffer. This feature makes efficient multi-drop communication simple to implement by removing the burden of the Transmit buffer enable control from the software. Programmers may find this feature useful when trying to implement multi-drop systems using Application software that does not support control of the transmitter. The port can simply installed as a Special Half-Duplex port via the driver. The application software will then treat the port as it would any other. Transmit buffer enabling and disabling will then take place automatically. Special Half-Duplex mode requires the Windows NT & 95 driver supplied. Selection of this mode is by means of jumper links and device driver options.

One interesting example of a case where the system engineer may easily take advantage of the advanced features of the card without resort to bespoke software design. Take the case of a SCADA system using an off the shelf SCADA type program set up to talk to COM3: RS-232 to a single external slave.

If the user replaces COM3 with a PCI248H<sup>2</sup> card and installs the port as a Special Half Duplex RS-485 port using the device driver, the same software will then operate multi-drop half duplex RS-485 talking to a number of external slave devices. The RS-485 transmit buffer will be enabled when data is ready to be sent under control of the device driver.

The PCI247H<sup>2</sup>-9H<sup>2</sup> Series board will often be used within an application specific program, and the user will integrate the serial communications operations into the bespoke program.

**APPENDIX A TECHNICAL SPECIFICATIONS**

Figures given in the specification are typical at 25° C, except where otherwise stated.

**App A1 HARDWARE SPECIFICATION****App A1.1 Function**

The PCI247H<sup>2</sup><sub>i</sub>, PCI248H<sup>2</sup><sub>i</sub> and PCI249H<sup>2</sup><sub>i</sub> provide a range of Serial Communications Boards with the serial data and control lines electrically isolated from the confines of the host PC. The PCI247H<sup>2</sup>, PCI248H<sup>2</sup> and PCI249H<sup>2</sup> provide a similar range of boards without the isolation feature.

The six boards in the range each provide two independent serial communications interfaces, but differ in their support of the standards:

<b>PCI247H<sup>2</sup> and PCI247H<sup>2</sup><sub>i</sub></b>	<b>Channel 1 (Upper)</b>	<b>Channel 2 (Lower)</b>
Communications I/O Connector	RS-232 9 way male D	RS-232 9 way male D
<b>PCI248H<sup>2</sup> and PCI248H<sup>2</sup><sub>i</sub></b>	<b>Channel 1 (Upper)</b>	<b>Channel 2 (Lower)</b>
Communications I/O Connector	RS-422/485 9 way male D	RS-422/485 9 way male D
<b>PCI249H<sup>2</sup> and PCI249H<sup>2</sup><sub>i</sub></b>	<b>Channel 1 (Upper)</b>	<b>Channel 2 (Lower)</b>
Communications I/O Connector	RS-232 9 way male D	RS-422/485 9 way male D

**App A1.2 RS-232 Port****App A1.2.1 9 way Connector**

Used on PCI247H<sup>2</sup>, PCI247H<sup>2</sup><sub>i</sub>, PCI249H<sup>2</sup> and PCI249H<sup>2</sup><sub>i</sub> RS-232 ports.

9 way, male D connector with metal shell. Pinouts to IBM input/output standard. For the isolated versions, all signals are referred to the remote device signal ground. The connector shell is connected to the local PC chassis ground.

**App A1.2.2 Configuration**

PCI247H<sup>2</sup>, PCI247H<sup>2</sup><sub>i</sub>, PCI249H<sup>2</sup> and PCI249H<sup>2</sup><sub>i</sub> RS-232 ports are configured as Data Terminal Equipment (DTE)

**App A1.2.3 Rx Voltage Levels**

RS-232 receivers - RXD, DCD, DSR, CTS and RI

	Min	Typ	Max
Input threshold low (V)	0.8	1.3	
Input threshold high (V)		1.7	2.4
Input hysteresis (V)	0.1	0.4	1.0
Input resistance (kΩ)	3	5	7

**App A1.2.4 Tx Voltage Levels**

RS-232 drivers - TxD, DTR and RTS

		Min	Typ	Max
Output voltage swing (Loaded 3 kΩ to Gnd)	Pos (V)	+5.0	+7.3	
	Neg (V)		-6.5	-5.0
Output short circuit current (mA)			±17	

**App A1.2.5 Data Rate**

The card is capable of error free transmission at data rates up to 1 Mbaud.

The drivers support speeds up to 2.5 MBaud but this speed can only be achieved with the RS-485 options, Windows NT, short distances, a fast PC and good cable.

**App A1.2.6 I/O Isolation**

For the isolated versions, each RS-232 interface is electrically isolated from the host PC circuit, with no common connections to the other port. Signal isolation is by opto-couplers on the data and control lines and power to the drivers/receivers is supplied through an isolated DC-DC converter.

Isolation specifications measured between Reference Signal Ground of the external device and Chassis Ground of the host PC are:-

Maximum test voltage	±400 Vpk
Maximum user applied voltage (Short duration)	±250 Vpk
Maximum user applied voltage DC (Sustained)	±75 VDC
Maximum user applied voltage AC (Sustained)	50 VAC
Typical on-board common mode Impedance	1 MΩ in parallel with 1 nF

**App A1.2.7 I/O Protection**

Driver outputs and receiver inputs can be shorted beyond the RS-232 fault limits to ±30 V without damage.

**App A1.2.8 ESD Protection**

The RS-232 line input/outputs have on-chip protection from ESD transients up to  $\pm 8$  kV for human body model discharges.

**App A1.3 RS-422/485 Port**

**App A1.3.1 9 way Connector**

Used on PCI248 H<sup>2</sup>/ PCI248H<sup>2</sup>i channel 1 upper and channel 2 lower ports and PCI249H<sup>2</sup>/PCI249H<sup>2</sup>i channel 2 lower port.

9 way, male D connector with metal shell. For the isolated versions, all signals are referred to the remote device signal ground. The connector shell is connected to the local PC chassis ground.

**App A1.3.2 Rx Voltage Levels**

RS-422/485 receiver - RXD and CTS

	Min	Typ	Max
Differential threshold voltage (V) ( $-7 \leq V_{cm} \leq 12$ V)	-0.2		0.2
Receiver input hysteresis (mV) ( $V_{cm} = 0$ V)		70	
Receiver input resistance (k $\Omega$ ) ( $-7 \leq V_{cm} \leq 12$ V)		12	

**App A1.3.3 Rx I/P Termination**

120  $\Omega$  resistor across differential input terminals of both Rx Data and CTS receivers. For multi-drop applications, the Rx data line termination resistor can be disconnected by removing a jumper.

**App A1.3.4 Tx Voltage Levels**

RS-422/485 driver - TXD and RTS

	Min	Typ	Max
Differential driver output (no load)			5 V
Differential driver output (with load)	Load = 50 $\Omega$ (RS-422)	2 V	5 V
	Load = 27 $\Omega$ (RS-485)	1.5 V	5 V
Driver common mode output voltage		3 V	
Differential output load resistance			27 $\Omega$

**App A1.3.5 Tx O/P Protection**

Excessive output current and power dissipation caused by faults or bus contention are prevented by two mechanisms. A fold-back current limit provides immediate protection against short circuits and thermal protection forces the driver into a high impedance state if the die temperature exceeds the limits.

**App A1.3.6 I/O Isolation**

Each RS-422/485 interface is isolated to the same specification as the RS-232 interface in A1.2.7

**App A1.3.7 ESD Protection**

The RS-422/485 line input/outputs have on-chip protection from ESD transients up to  $\pm 8$  kV for human body model discharges.

**App A1.4 Modes**

Full Duplex, Half Duplex, Special Half Duplex, Multi-drop, Broadcast

**App A1.4.1 Transmit Turnaround**

Transmission turnaround by the RTS control line is used in RS-485 half-duplex operation.

When the /RTS line of the UART is low (active), the RS-485 transmission is enabled. When /RTS is high (inactive), RS-485 reception is enabled. Default condition is reception enabled.

Activation of /RTS is under control of the control of software as a default. The UART also allows for hardware control of /RTS. In this mode /RTS is activated when data is present in the transmit buffer. Selection of hardware control of /RTS requires special software, such as The Windows device drivers available from Amplicon.

By external loop-back of the RTS-CTS differential lines, the instantaneous status of the control signal can be monitored.

**App A1.5 UARTS**

Two 16C950 Universal Asynchronous Receiver-Transmitters (UARTs) with FIFOs. The UARTs default to the condition where all registers are similar to the 16C550.

**App A1.5.1 Baud Rates**

All standard rates from 50 baud to 2.5 MBaud can be generated.

**App A1.5.2 Data Bits**

Programmable 5, 6, 7 or 8.

**App A1.5.3 Stop Bits**

Programmable 1 or 2

**App A1.5.4 Parity**

Programmable Even, Odd or None

**App A1.6 Interrupts**

When the interrupts are enabled, each channel generates an interrupt request whenever a receiver error, receiver data available, transmitter empty or modem status condition flag is detected.

**App A1.6.1 Interrupt Levels**

The interrupt signal from each channel can be assigned any available IRQ levels.

**App A1.6.2 Interrupt Control**

Interrupts can be individually masked by bits 0-3 of the UART Interrupt Enable Register. All interrupts can be globally enabled/disabled by bit 3 of the UART Modem Control Register.

**App A1.7 Power-up Default**

Under RESET conditions, the UART emulates the 16C550. Operation with the supplied software configures the card for high-speed operation.

**App A1.8 PC Interface****Compatibility**

PCI Bus revision 2.1 compatible.

**Base Address**

Automatically assigned in I/O space.

Registers occupy 8 contiguous locations above each base address.

**Interrupt Levels**

Plug and Play configurable onto any available PC IRQ

**Power Requirements**

+5 VDC from PC I/O bus. Current required from +5 V PC supply: All Tx Data lines fully loaded.

PCI247H <sup>2</sup> -9H <sup>2</sup> Series	260 mA typical operating
PCI247H <sup>2</sup> -9H <sup>2</sup> (i) Series	300 mA typical operating

**Multiple Boards**

Any number of the specified boards in any combination, commensurate with physical space, I/O address space and power availability can be supported in a single PC.

**App A2 SOFTWARE**

The distribution software is supplied on a CD-ROM.

Windows 95, 98, ME, NT, 2000, and XP Driver Software provides Application level access to all the advanced features of the card from these operating systems.

**App A3 ENVIRONMENTAL CONDITIONS****App A3.1 Environment**

All boards in the PCI247H<sup>2</sup>-9H<sup>2</sup> Series are designed to operate in a PCI version 2.1 PC/AT environment

**App A3.2 Specific conditions**

<b>I/O Positions Required</b>	One, half length, standard PCI slot
<b>Board Dimensions</b>	Length    ≈157 mm (Minimum length) Height    ≈99 mm plus edge connectors.
<b>Temperature Range</b>	Operating 0° C to +60° C Storage    -20 to +70° C
<b>Power Requirements</b>	+5 VDC at up to 300 mA maximum from host PC power supply.
<b>Dissipation</b>	Each board will dissipate less than 1.6 Watts of heat.
<b>Handling</b>	Normal static handling precautions apply. Damage could result if not observed

**App A3.3 Electro Magnetic Compatibility**

(89/336/EEC)  
Electro-Magnetic Compatibility

All boards in the PCI247H<sup>2</sup>-9H<sup>2</sup> Series comply with the European directive 89/336/EEC

**App A4 ORDER CODES**

The Order Code for the PCI247H<sup>2</sup> is 96986503

The Order Code for the PCI247H<sup>2</sup>i is 96986513

The Order Code for the PCI248H<sup>2</sup> is 96986523

The Order Code for the PCI248H<sup>2</sup>i is 96986533

The Order Code for the PCI249H<sup>2</sup> is 96986543

The Order Code for the PCI249H<sup>2</sup>i is 96986553

**APPENDIX B LAYOUT AND CIRCUIT DIAGRAMS**

Layout and circuit diagrams are given in this appendix to cover all variations of the PCI247H<sup>2</sup>(i), PC2I49H<sup>2</sup>(i) and PCI249H<sup>2</sup>(i).

**App B1 Layout Diagrams**

Figures B.1, B.2 and B.3 provide layout diagrams for the PCI247H<sup>2</sup>i, PCI248H<sup>2</sup>i and PCI249H<sup>2</sup>i respectively. These layout diagrams show all the components for the isolated versions.

The non-isolated versions have printed circuit links retained across the drill points and do **not** have the following components fitted:

<b>PCI247H<sup>2</sup></b>		<b>PCI248H<sup>2</sup></b>		<b>PCI249H<sup>2</sup></b>	
<b>Channel 1</b>	<b>Channel 2</b>	<b>Channel 1</b>	<b>Channel 2</b>	<b>Channel 1</b>	<b>Channel 2</b>
U19	U31	U19	U31	U19	U31
U11	U23	U11	U23	U11	U23
U12	U24	U12	U24	U12	U24
U13	U25	U13	U25	U13	U25
U14	U26	U14	U26	U14	U26
U15	U27	U15	U27	U15	U27
U16	U28	U16	U28	U16	U28
U17	U29	U17	U29	U17	U29
U18	U30	U18	U30	U18	U30
U20	U32	U10	U22	U20	U22
U21	U33			U21	
R3	R29	R3	R29	R3	R29
R4	R30	R4	R30	R4	R30
R5	R31	R5	R31	R5	R31
R6	R32	R6	R32	R6	R32
R7	R33	R7	R33	R7	R33
R8	R34	R8	R34	R8	R34
R9	R35	R9	R35	R9	R35
R10	R36	R10	R36	R10	R36
R11	R37	R11	R37	R11	R37
R12	R38	R12	R38	R12	R38
R13	R39	R13	R39	R13	R39
R14	R40	R14	R40	R14	R40
R15	R41	R15	R41	R15	R41
R16	R42	R16	R42	R16	R42
R17	R43	R17	R43	R17	R43
R18	R44	R18	R44	R18	R44

### App B2 PCI247H<sup>2</sup>(i) Circuit and Layout Diagrams

Figure B.5 shows the circuit diagram of the dual channel RS-232 input/output circuits and Figure B.1 below shows the layout of the PC247H<sup>2</sup>i. The devices required for isolation are indicated by bold typeface in the list below, and these components are **not** fitted to the PCI247H<sup>2</sup> (non-isolated). The principal devices and their functions are identified in the following list:-

Device	Type	Function
<b>U11/23</b>	HCPL0600	Opto-coupler for Channel 1/2 'Received Data' line to the UART.
<b>U12/24</b>	HCPL0600	Opto-coupler for Channel 1/2 'Transmit Data' line to the UART.
<b>U13/25</b>	HCPL0600	Opto-coupler for Channel 1/2 'DSR' line to the UART.
<b>U14/26</b>	HCPL0600	Opto-coupler for Channel 1/2 'DTR' line to the UART.
<b>U15/27</b>	HCPL0600	Opto-coupler for Channel 1/2 'CTS' line to the UART.
<b>U16/28</b>	HCPL0600	Opto-coupler for Channel 1/2 'RTS' line to the UART.
<b>U17/29</b>	HCPL0600	Opto-coupler for Channel 1/2 'RI' line to the UART.
<b>U18/30</b>	HCPL0600	Opto-coupler for Channel 1/2 'DCD' line to the UART.
<b>U10/22</b>	MAX3245	RS-232 Driver/receiver for Channel 1/2 control, and data lines.
<b>U19/31</b>	SI-0505ND	DC-DC Converters for supplying power to Channel 1/2 isolated circuits
<b>PL60</b>		9 way male D connector for Channel 1 RS-232 input/output
<b>PL80</b>		9 way male D connector for Channel 2 RS-232 input/output

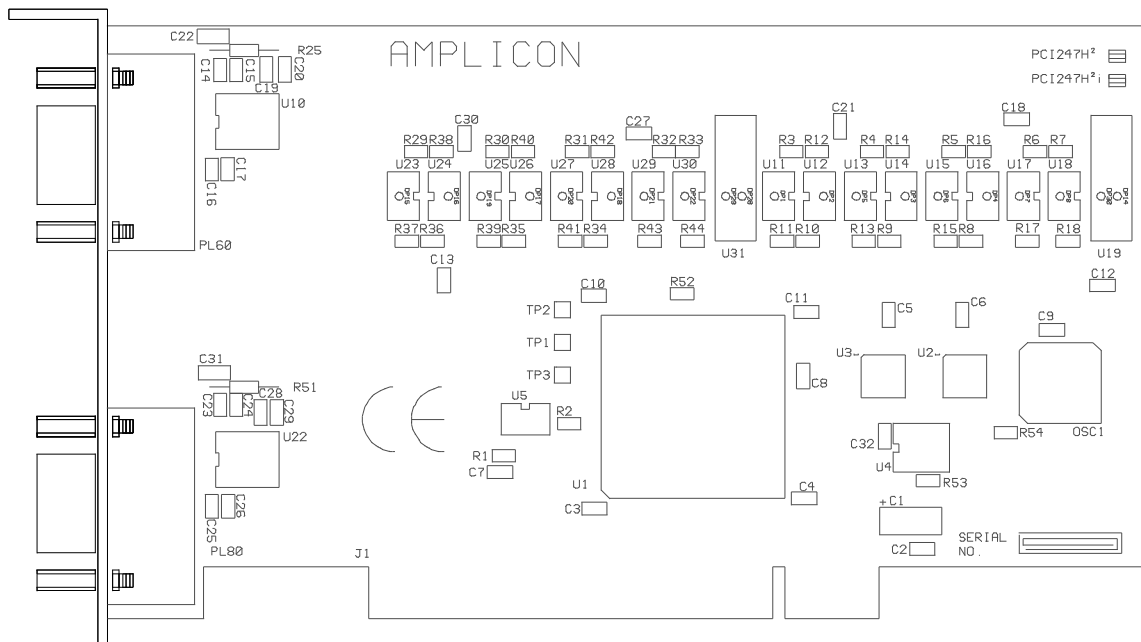
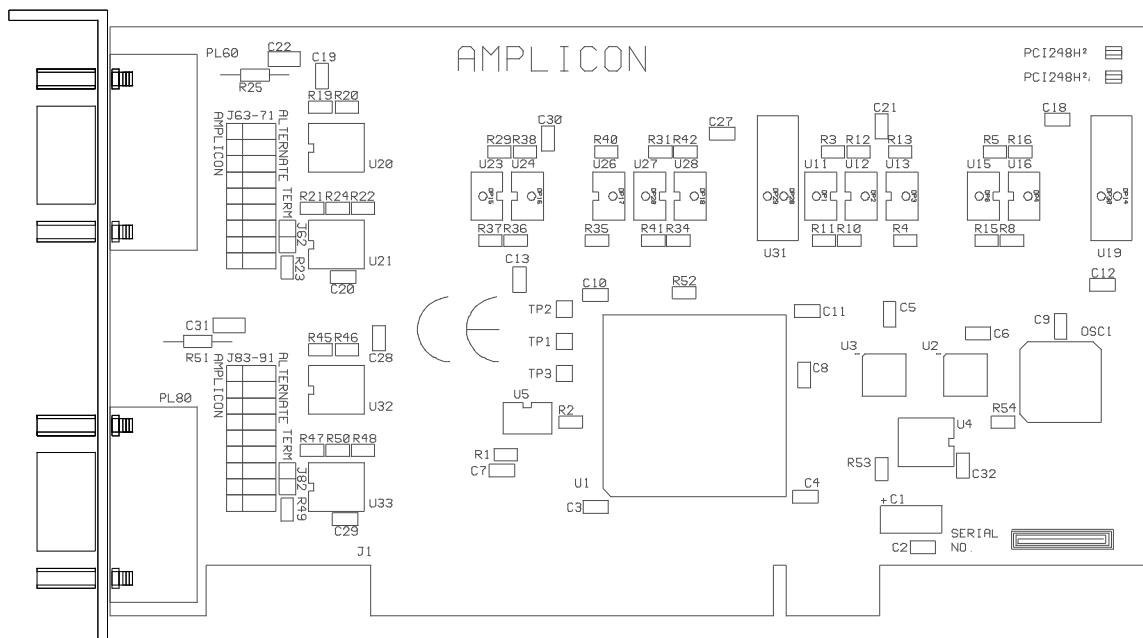

**FIGURE B.1 PCI247H<sup>2</sup>i LAYOUT DIAGRAM**

**App B3 PCI248H<sup>2</sup>(i) Circuit and Layout Diagrams**

Figure B.6 shows the circuit diagram of the dual channel RS-422/485 input/output circuits and Figure B.2 below shows the layout of the PCI248H<sup>2</sup>i. The devices required for isolation are indicated by bold typeface in the list below, and these components are **not** fitted to the PCI248H<sup>2</sup> (non-isolated). The principal devices and their functions are identified in the following list:-

Device	Type	Function
<b>U11/23</b>	HCPL0600	Opto-coupler for Channel 1/2 'Received Data' line to the UART.
<b>U12/24</b>	HCPL0600	Opto-coupler for Channel 1/2 'Transmit Data' line to the UART.
<b>U14/26</b>	HCPL0600	Opto-coupler for Channel 1/2 'DTR' line to the UART.
<b>U15/27</b>	HCPL0600	Opto-coupler for Channel 1/2 'CTS' line to the UART.
<b>U16/28</b>	HCPL0600	Opto-coupler for Channel 1/2 'RTS' line to the UART.
<b>U20,21</b>	MAX3086	RS-485 Driver/receivers for Channel 1/2 control, and data lines.
<b>/U32,33</b>		
<b>U19/31</b>	SI-0505ND	DC-DC Converters for supplying power to Channel 1/2 isolated circuits
<b>PL60</b>		9 way male D connector for Channel 1 RS-422/485 input/output
<b>PL80</b>		9 way male D connector for Channel 2 RS-422/485 input/output



**FIGURE B.2 PCI248H<sup>2</sup>i LAYOUT DIAGRAM**

## App B4 PCI249H<sup>2</sup>(i) Circuit and Layout Diagrams

Figure C.7 shows the circuit diagram of the RS-232 (Channel 1) and RS-422/485 (Channel 2) input/output circuits and Figure C.3 below shows the layout of the PCI249H<sup>2</sup>i. The components required for isolation are indicated bold typeface in the list below, and these components are **not** fitted to the PCI249H<sup>2</sup> (non-isolated). The principal devices and their functions are identified in the following list:-

Device	Type	Function
<b>U11/23</b>	HCPL0600	Opto-coupler for Channel 1/2 'Received Data' line to the UART.
<b>U12/24</b>	HCPL0600	Opto-coupler for Channel 1/2 'Transmit Data' line to the UART.
<b>U13/25</b>	HCPL0600	Opto-coupler for Channel 1/2 'DSR' line to the UART.
<b>U14/26</b>	HCPL0600	Opto-coupler for Channel 1/2 'DTR' line to the UART.
<b>U15/27</b>	HCPL0600	Opto-coupler for Channel 1/2 'CTS' line to the UART.
<b>U16/28</b>	HCPL0600	Opto-coupler for Channel 1/2 'RTS' line to the UART.
<b>U17/29</b>	HCPL0600	Opto-coupler for Channel 1/2 'RI' line to the UART.
<b>U18/30</b>	HCPL0600	Opto-coupler for Channel 1/2 'DCD' line to the UART.
<b>U10</b>	MAX3245	RS-232 Driver/receiver for Channel 1 control, and data lines.
<b>U32,33</b>	MAX3086	RS-485 Driver/receivers for Channel 2 control, and data lines.
<b>U19/31</b>	SI-0505ND	DC-DC Converters for supplying power to Channel 1/2 isolated circuits
<b>PL60</b>		9 way male D connector for Channel 1 RS-232 input/output
<b>PL80</b>		9 way male D connector for Channel 2 RS-422/485 input/output

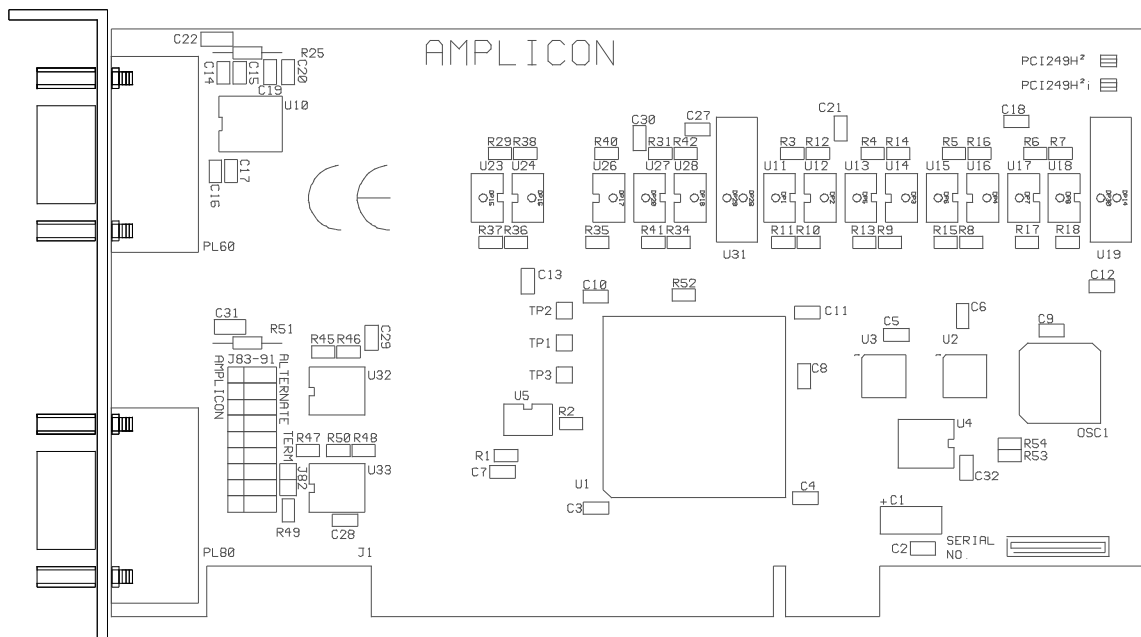

FIGURE B.3 PCI249H<sup>2</sup>i LAYOUT DIAGRAM

**App B5      Circuit Diagram      PCI247H<sup>2</sup>-9H<sup>2</sup>(i) - All Versions**

Figure B.4 shows the circuit of the section that is common to all versions of the PCI247H<sup>2</sup>-9H<sup>2</sup>(i) boards. This circuit diagram includes the PC interface and dual UART. The principal devices and their functions are listed below:-

<b>Device</b>	<b>Type</b>	<b>Function</b>
U2/U3	16C950 UART	Universal Asynchronous Receiver-Transmitter. Performs the parallel/serial and serial/parallel conversion of data received from the PC on transmission and the external lines on reception. Status registers indicate error conditions and transfer operations. Internal FIFOs store up to 128 bytes each of transmitted or received data.
U1	PCI9050	PCI bus interface.
U5	93CS46	EEPROM storing configuration data for PCI Bus interface.
OSC1	40 MHz Oscillator	Provides accurate, stable crystal oscillator source for the UART baud rate generators when UART is operating at higher data rates under advanced options.

App B6      USER'S NOTES - DRAWINGS

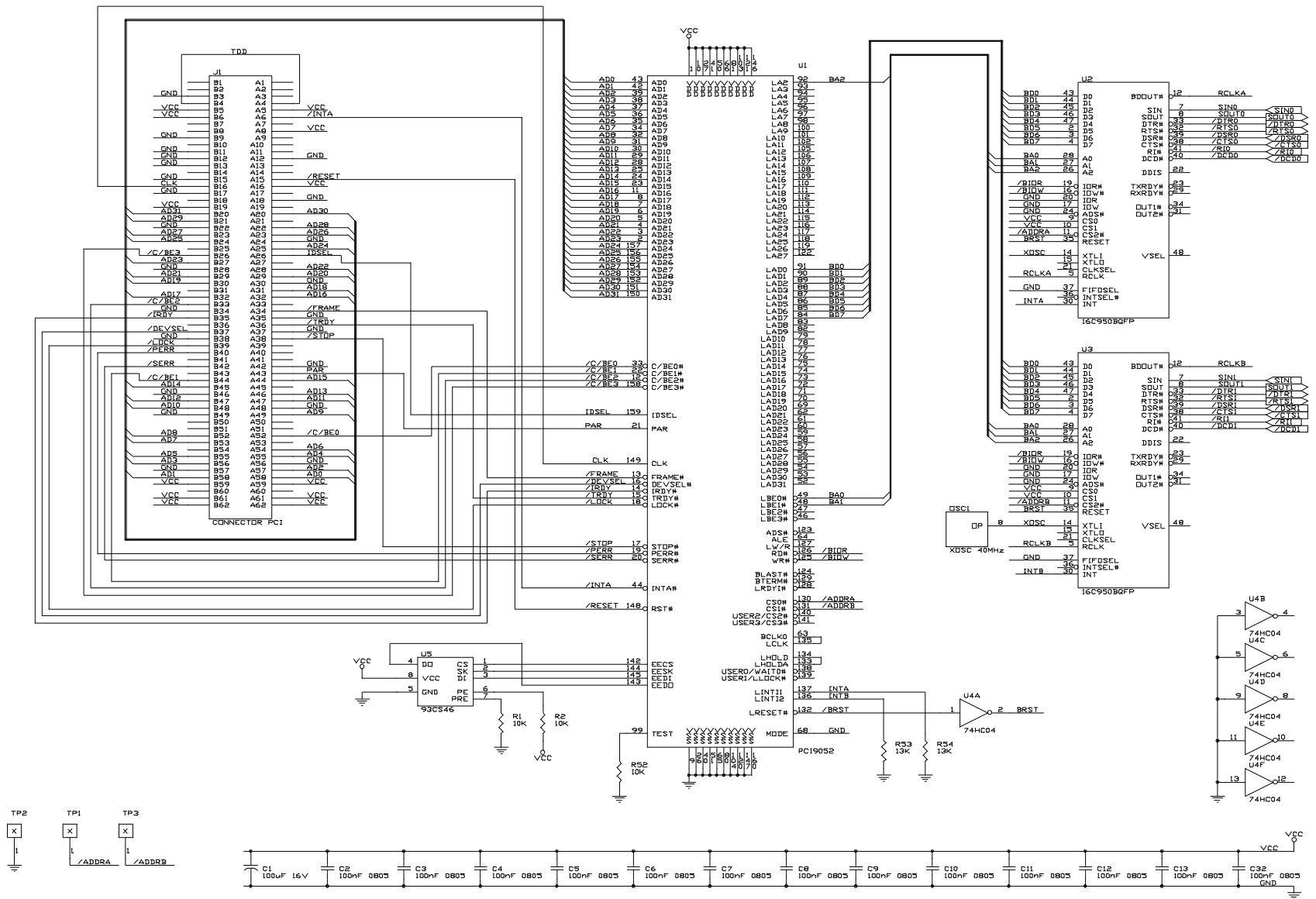

**FIGURE B.4 PCI247H<sup>2</sup>-9H<sup>2</sup> CIRCUIT SCHEMATIC PC INTERFACE AND UARTS**

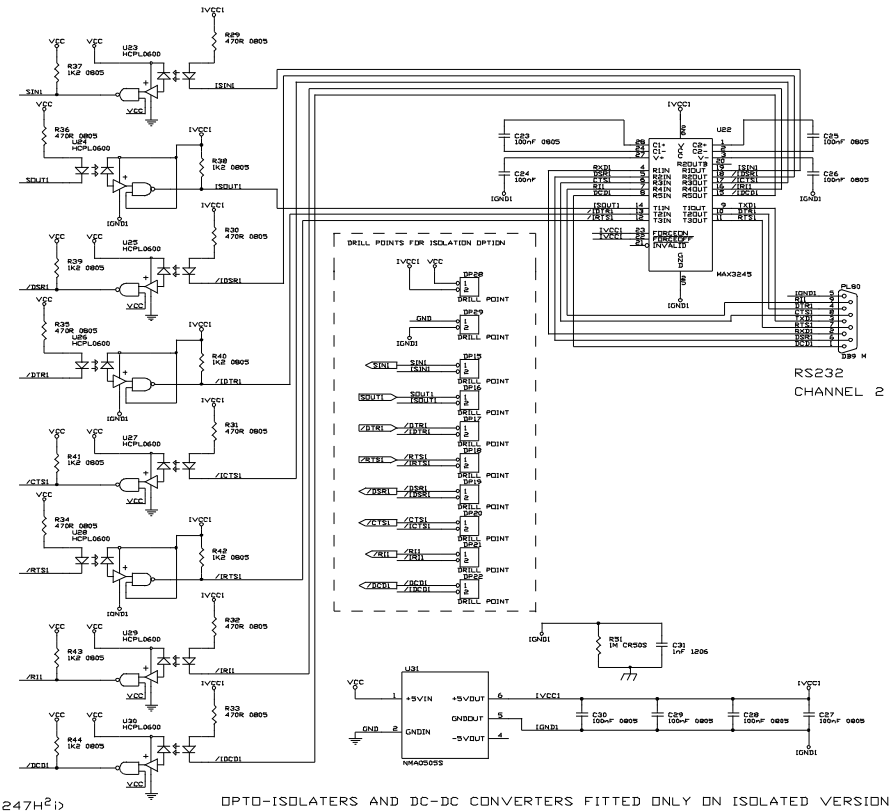
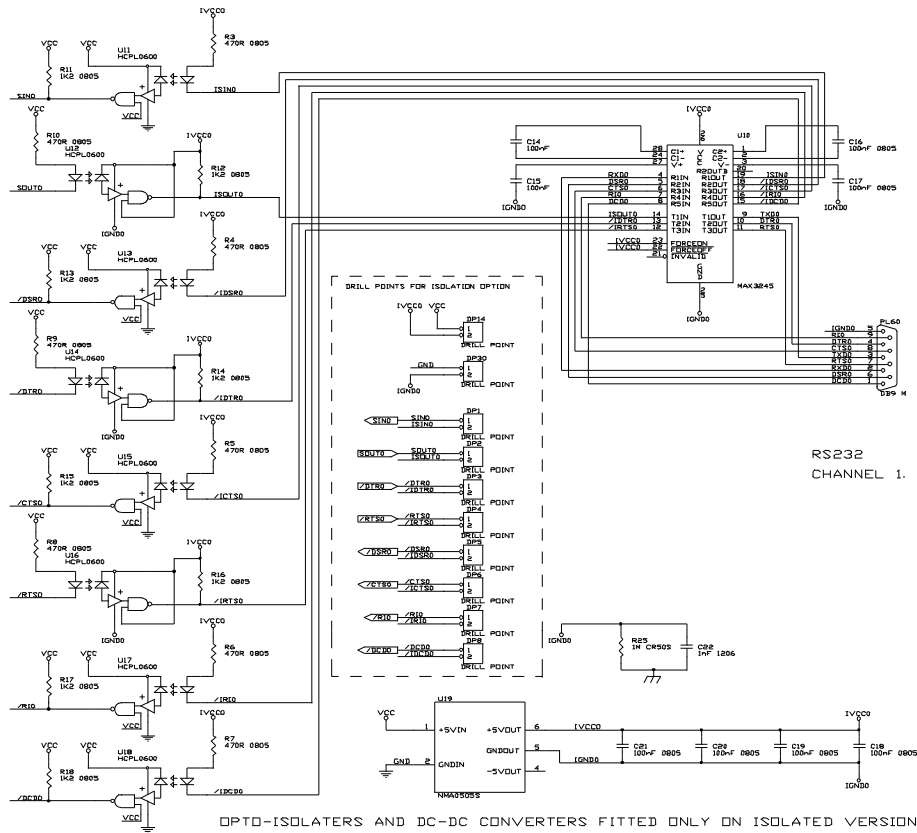

**FIGURE B.5** PCI247H<sup>2</sup>(I) CIRCUIT SCHEMATIC DUAL CHANNEL RS-232 I/O



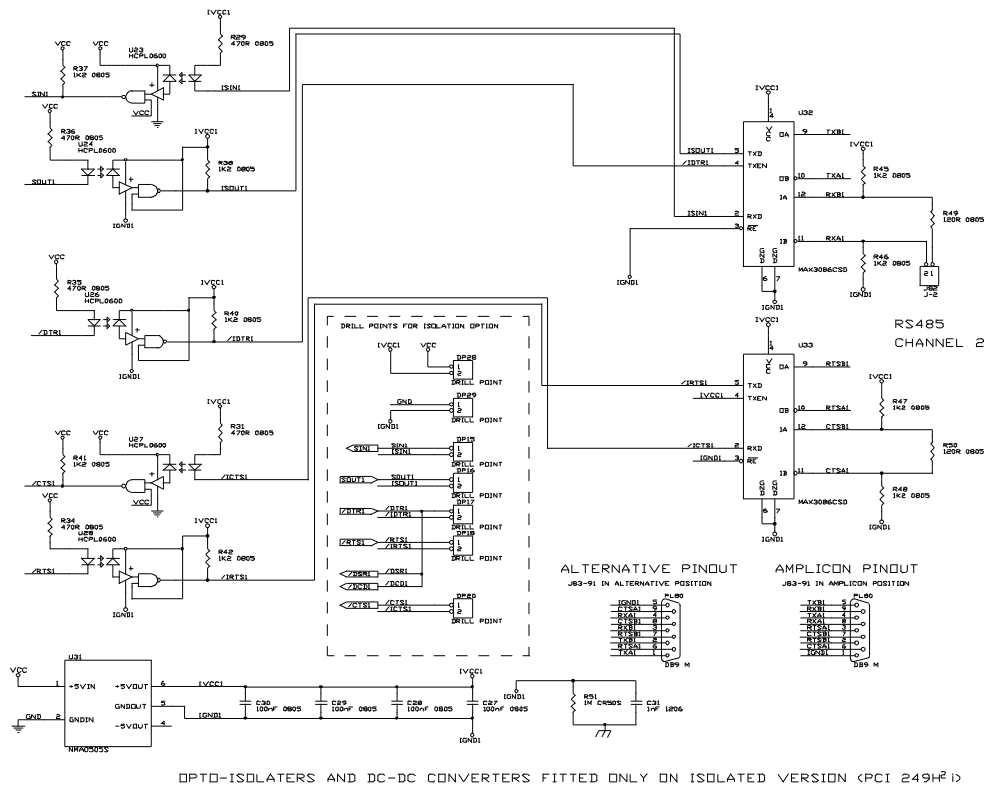
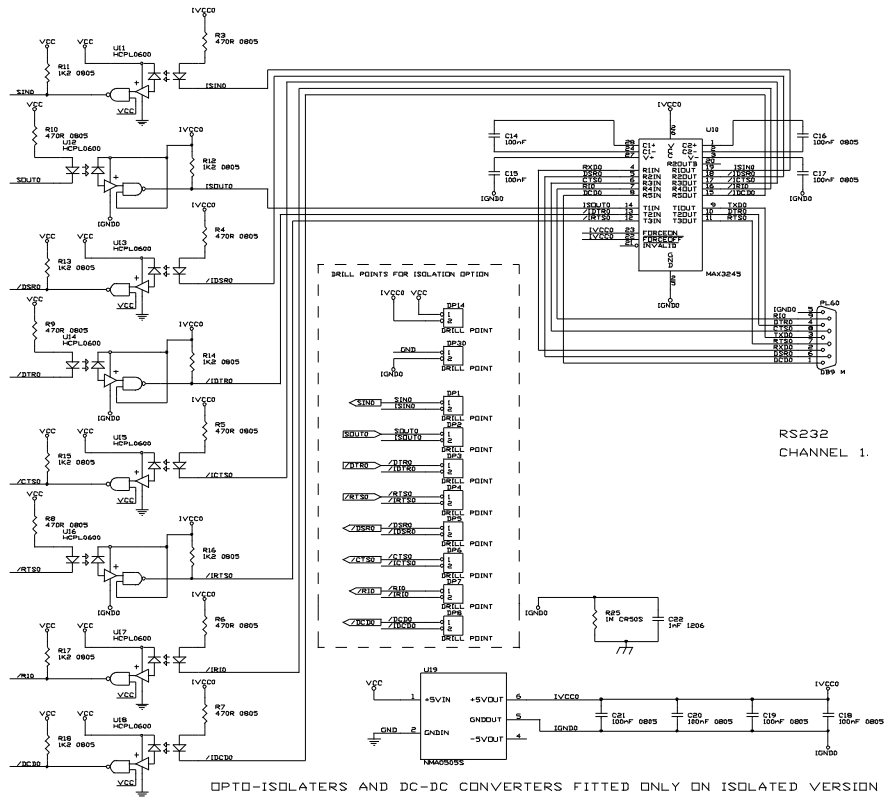

FIGURE B.7 PCI249H<sup>2</sup>(I) CIRCUIT SCHEMATIC RS-232 AND RS-422/485 I/O