



2-Port Serial Server

■ ■ SE5002

RoHS-compliant

Features

- Rugged metal case with DIN-Rail/wall-mount
- 15KV ESD protection for serial signals
- 10/100Mbps Fast Ethernet full duplex auto negotiation
- Support multiple link mode with TCP server/client, UDP and Virtual COM mode
- Monitor, manage and control industrial field devices remotely
- Configuration: Built-in Web Server /Serial Console/ Telnet
- Windows Base utility for IP configuration
- Upgrade firmware from remote-PC via Ethernet

Make Serial Devices Ready to the Network

The Industrial Serial Server SE5002 is a dual port gateway between Ethernet (TCP/IP) and serial signal communications. It allows almost any serial device to be connected to a new or existing Ethernet network.

By encapsulating serial data and transporting it over Ethernet, SE5002 offers full-duplex, bi-directional data transmission transparent between serial port and Ethernet network.

Easy to Use

Flexible configuration options enable this unit to be setup over Ethernet by Telnet, Web browser, Serial Console, or other Windows utilities. Packed in a rugged metal housing for wall or DIN-Rail mount with 9~30VDC wide power input range, SE5002 is ideal for almost any industrial and manufacturing automation.

ATOP Virtual COM software provides existing Windows based application to access serial device by mapping to remote serial server via Ethernet.

Specially Designed for Automation Fields

In industrial and manufacturing automation fields, SE5002 is used as a field device to connect Ethernet through TCP/IP protocol directly. It is also specially designed for conjunction with PLCs, HMIs, Barcode Scanners, Data Terminals, Electronic Kanbans, Shop Floor Control Systems, and Pick-to-Light Systems.

2-Port Serial Server



Specifications	
CPU	16-bit Embedded CPU
Flash Memory	512 KBytes
SDRAM	512 KBytes
EEPROM	512 Bytes
Network Interface	10/100Mbps Fast Ethernet
Network Protocol	TCP/IP, UDP, HTTP, SNMP, ARP, Telnet, ICMP, BOOTP, DHCP
Reset	Built-in reset key to restore the defaults
Serial Interface	RS-232/RS-485/RS-422 or RS-485/RS-422 (by model)
Serial Connector	DB9 male for SE5002, TB5 (Lockable) for SE5002-S55is
Serial Communication	Data Rate: 1200 bps~230 Kbps Characters: 7 or 8 data bits Parity: None, Even, Odd, Mark, Space Stop Bits: 1 or 2 Flow Control: Xon/Xoff, RTS/CTS
LED Indicator	LAN, RUN and COM
Power Requirement	9~30VDC, 1A
Temperature	Operation: 0°C~ 60°C, Storage : -20°C~70°C
Humidity	20%~90% non-condensing
Dimension	85mm x 75mm x 28mm (W x H x D)
Software	Windows OS based Configuration Utility, Virtual COM software
Configuration	Web, Telnet, Serial Console and Windows based Configuration Utility
Ordering Information (by Model)	
SE5002	Dual port (DB9 connector) serial server, RS232/RS422/RS485 software selectable, without adapter
SE5002-S55is	Dual RS-485/RS-422 port (TB5 connector Lockable) isolation serial server without adapter
Optional Accessories	
DK-25	DIN-Rail Kit
1A25F (US)	Power adapter (US), AC100~240V/DC 12V 1.25A with DC Jack for SE5002 (Lockable)
1A25F (EU)	Power adapter (EU), AC100~240V/DC 12V 1.25A with DC Jack for SE5002 (Lockable)
US315-12 (US)	Power adapter (US), AC100~240V/DC 12V 1.25A with Terminal block for SE5002-S55is
USE315-12 (EU)	Power adapter (EU), AC100~240V/DC 12V 1.25A with Terminal block for SE5002-S55is



TCP Server Mode

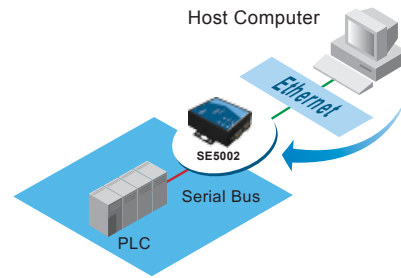

TCP Client Mode

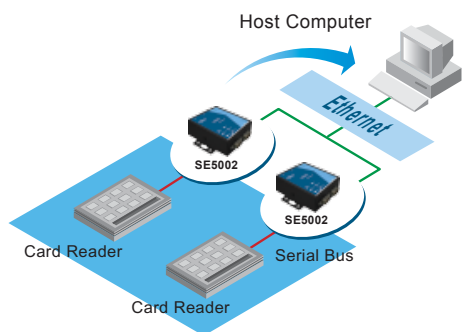

UDP Mode

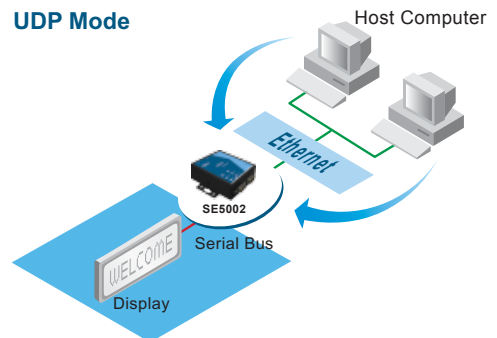

Tunneling Mode

