

ES2163 Ethernet Analog Input Modules

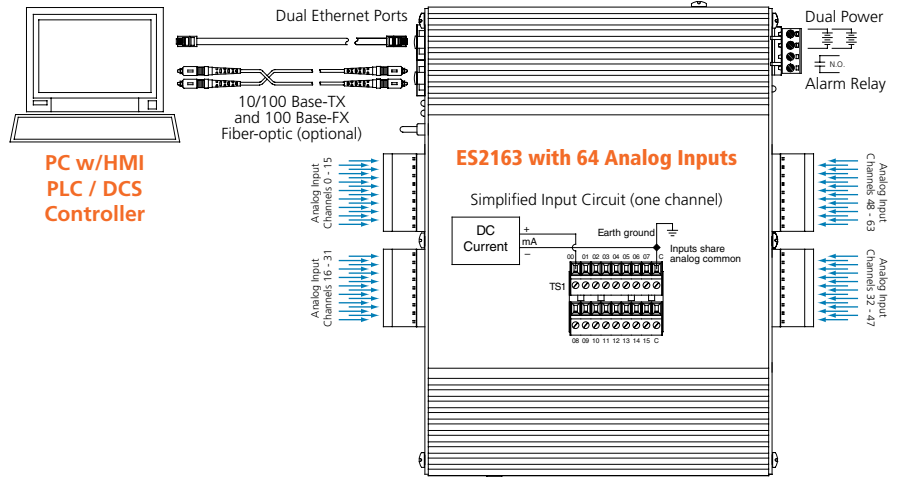

64-channel single-ended analog current input ♦ Modbus TCP/IP or UDP/IP communication

Description

These EtherStax I/O modules provide a rugged, high-density, and high-speed solution to interface a large quantity of analog input signals to SCADA and distributed I/O systems. Each unit converts up to 64 single-ended analog current signals from various sensors and instruments for transmission to an Ethernet-based control network. Typical applications include process control, automated manufacturing, remote data acquisition, test and measurement, embedded computing, and supervisory monitoring systems.

EtherStax units are built and tested to deliver high reliability and dependable performance in hostile environments. Many features help increase reliability, improve performance and protect from harsh environments. Available in an aluminum enclosure or as an open circuit board, both formats stack vertically to maintain a very small footprint.

Input Ranges

±20mA, 0-20mA, 4-20mA DC

Ethernet Communication

10/100Base-T(X) and 100Base-FX, Automatic MDI/MDI-X on all copper ports, Modbus TCP/IP or UDP/IP protocol

Power Requirement

18 to 36V DC (redundancy-ready)

Approvals

CE, UL/cUL (pending):
Zone 2, Class 1, Division 2, Groups ABCD



Open circuit board versions are also available.

Key Features & Benefits

- 64 single-ended analog current inputs
- 4-way isolation and surge suppression
- High-resolution 16-bit A/D
- High-speed scanning with 10 millisecond update of all 64 channels
- Automatic zero/span calibration
- On-demand self-test verifies calibration
- Configurable from any web browser
- User-configurable sample averaging and integration/totalization function with non-volatile registers
- Dual-format data registers support 16-bit integers or 32-bit floating point
- Scaling registers on all channels

Performance Specifications

Analog Field Inputs

Input Channel Configuration

64 single-ended analog inputs. 32 channels on front and rear panels of unit.

DC Current Input Ranges

±20mA, 0-20mA, or 4-20mA DC (default).
User-configured on a per-channel basis.

Input Scaling (per-channel basis)

Floating Point Format: IEEE-754 32-bit configurable for 12 digits with 4 decimal places.

16-bit Signed Integer Format: All channels represented as ±30,000.

Input Resolution and Accuracy

Resolution: 15-bit maximum, 0.003%.
Accuracy: Better than 0.1% of range.

Input Impedance

100 ohms.

Input Scan Groups and Scan Times

Eight user-enabled 8-channel scan groups.
10mS (100Hz) update of all 64 channels.

First 8-channel group updates in 1.80mS (555Hz).
Each additional 8-channel group adds 1.20mS to the update time.

Sample Averaging

0 to 500 samples, user-configurable.

Input Overvoltage Protection

Bipolar Transient Voltage Suppressors (TVS),
14V working voltage.

Noise Rejection

Common Mode (50-60Hz): Better than 72dB.

Local Alarm Output

Configuration

Failsafe or non-failsafe (software-configurable) relay trips on power or link-loss failure.

Type

SPST-NO, 1 Form A, Class I, Division II approved.

Rating

5A @ 24V DC/250V AC, 6000 cycles resistive.
3A @ 24V DC/250V AC, 100,000 cycles general.
2A @ 24V DC/250V AC, Hazardous locations.

Maximum Switching Voltage and Power
250V AC / 750VA, 125V DC / 90W.

Ethernet Interface

Internal Switch or Hub/Repeater

Dual-port Ethernet switch. Web-configurable as a true switch (default mode) or low-latency hub.

Network Connector (10/100 Base-TX Copper)

One or two 8-pin RJ-45 connectors. Automatic MDI/MDI-X. 100m communication distance.

Network Connector (100 Base-FX Fiber-optic)

One multi-mode duplex SC connector. Full-duplex only. 2km communication distance.

Protocols and Addressing

Modbus TCP/IP or UDP/IP. StaticIP, DHCP, BootP. Configurable IP addresses.

Ethernet Modbus TCP/IP Sockets/Sessions

1-10 socket/sessions programmable via web page.

Ethernet Redundancy

Compatible with STP, RSTP, proprietary schemes.

Environmental

Operating and Storage Temperature

Operating Ranges:

IP20 Enclosure: -40 to 70°C (-40 to 158°F).

Open Board: -40 to 75°C (-40 to 167°F).

Storage Range: -40 to 85°C (-40 to 185°F).

Power Requirements

18-36V DC. Redundant, diode-coupled terminals.
4.4W (copper ports), 5.5W (fiber-optic ports).

Ambient Temperature Effect

Less than 35ppm/°C (0.0035%/°C).

Isolation

I/O, power, relay and Ethernet port-to-port.

Peak: 1500V AC, ANSI/ISA-82.01-1988.

Continuous: 250V AC, 354V DC.

Enclosure and Physical

Housing Classification and Dimensions

IP20: 8.226" x 2.444" x 7.25", 4 lbs. packed.

PCB: 7.920" x 1.875" x 7.25", 1.65 lbs. packed.

Safety Approvals (pending)

CE marked and UL/cUL Listed.

Hazardous Locations: Class I; Division 2; A, B, C, D.

Open board units: UL Recognized.

Shock and Vibration Immunity (in enclosure)

Mechanical Shock: 50g (3ms), 30g (11ms).

Random Vibration: 5g, (5-500Hz).

Ordering Information

EtherStax I/O Units

ES2163-0000

Current inputs, two Cu ports, IP20 enclosure

ES2163-0010

Current inputs, two Cu ports, open board

ES2163-1000

Current inputs, Cu & fiber ports, IP20 enclosure

ES2163-1010

Current inputs, Cu & fiber ports, open board

Accessories

See Manual 8500-825 for more information.

ESA-CTK

Cable termination kit. Adds secure IP20 clip-type connector to Cat-5 cable (including plug and sleeve).

ESA-DIN-HMK

ESA-DIN-VMK

DIN rail horizontal mounting kit (-HMK).

DIN rail vertical mounting kit (-VMK).

ESA-OMK

ESA-SMK

Open circuit board mounting kit (-OMK).

Surface mounting kit (-SMK).

ESW-MBLIB

Software Modbus TCP/IP C libraries. Includes source code and demo program. Ideal for Visual C, Linux, VxWorks, QNX, and OS9 environments.